

Sigen Energy Gateway C&I Series User Manual

Version: 07

Release date: 2025-12-22



Copyright Notice

Copyright© 2025 SigenergyTechnology Co., Ltd. All Rights Reserved.

Description in this document may contain predictive statements regarding financial and operating results, product portfolio, new technology, configurations and features of product. Several factors could cause difference between actual results and those expressed or implied in the predictive statements. Therefore, description in this document is provided for reference purpose only and constitutes neither an offer nor an acceptance. Sigenergy Technology Co., Ltd. may change the information at any time without notice.

 SIGENERGY and other Sigenergy trademarks are owned by Sigenergy Technology Co., Ltd.

All trademarks and registered trademarks in this document belong to their owners.



www.sigenergy.com

Contents

Revision History	05
Preface	06
Chapter 1 Safety Precautions	07
1.1 General Requirements	07
1.2 Personnel Requirements	09
1.3 Handling and Transportation Requirements	10
1.4 Storage Requirements	11
1.5 Operation Requirements	12
1.5.1 Equipment Installation	13
1.5.2 Cable Connections	15
1.5.3 Requirements for High-altitude Work	16
1.5.4 Equipment Maintenance and Replacement	17
Chapter 2 Product Introduction	18
2.1 Functions and Designation	18
2.2 Product Appearance Introduction	20
2.2.1 Sigen Gateway TPLV C30-2	20
2.2.2 Sigen Gateway C60-2	23
2.2.3 Sigen Gateway C60 AU	26
2.2.4 Sigen Gateway C120-6, TPLV C70-6)	29
2.2.5 Sigen Gateway (C180-9, C300-12)	31
2.2.6 Sigen Gateway (C600, C1200, C600-B, C1200-B)	33
2.3 Label Description	39
2.4 Supported Power Supply Methods for the Power Grid	40
2.5 Introduction to system wiring	41
Chapter 3 Location Requirements	51
Chapter 4 Equipment Installation and Wiring	55
Chapter 5 Searching for App	56
Chapter 6 System Maintenance	57
6.1 Equipment Power-Down	57

6.1.1 Sigen Gateway TPLV C30-2	57
6.1.2 Sigen Gateway C60-2	59
6.1.3 Sigen Gateway C60 AU	60
6.1.4 Sigen Gateway (C120-6, TPLV C70-6)	61
6.1.5 Sigen Gateway (C180-9, C300-12)	62
6.1.6 Sigen Gateway (C600, C1200, C600-B, C1200-B)	63
6.2 Routine Maintenance	64
6.3 Common Fault Troubleshooting	66
6.4 Operations on Bypass Switch	67
6.4.1 Steps for Closing the Bypass Switch	67
6.4.2 Procedure for disconnecting the bypass switch	69
6.5 Emergency Measures	70
Chapter 7 Technical Parameters	71

Revision History

Version	Date	Description
07	2025.11.21	UpdateStorage Requirements
06	2025.08.05	UpdateLocation Requirements
05	2025.06.19	AddSigen Gateway (C600, C1200, C600-B, C1200-B)
04	2025.05.07	Added Sigen Gateway C60 AU UpdateEquipment Power-Down
03	2025.04.22	Added Sigen Gateway C60-2 Updated Sigen Gateway (C120-6, TPLV C70-6) Updated Sigen Gateway (C180-9, C300-12) Updated site selection requirements UpdateSystem Maintenance
02	2024.09.27	AddedRequirements for High-altitude Work Added Sigen Gateway TPLV C30-2 Added Sigen Gateway (C180-9, C300-12) Updated label instructions Added supported grid types Updated networking introduction UpdatedEquipment Power-Down
01	2024.08.20	First official release.

Preface

Overview

This document mainly describes the product introduction, networking, and system maintenance of the SiGen Energy Gateway for the C&I series (hereinafter referred to as the Gateway).



Intended Audience

This document is intended for:

- Professionally trained and qualified installers.
- Technical support engineers.

Definitions of Signs

The following signs may be used in the document to indicate safety precautions or key information. Before installation and operation of the equipment, familiarize yourself with signs and their definitions.

Sign	Definition
 Danger	Danger. Indicates an imminently hazardous situation which, if not avoided, will result in death or serious personal injury.
 Warning	Warning. Indicates a potentially hazardous situation which, if not avoided, will result in serious personal injury or property damage.
 Caution	Caution. Indicates a potentially hazardous situation which, if not avoided, will result in property damage.
Tips	Indicates important or key information and provides operation tips.

Chapter 1 Safety Precautions

1.1 General Requirements

Before installing, operating, and maintaining the equipment, familiarize yourself with this user manual. Strictly follow the instructions in the manual and adhere to all safety precautions indicated on the equipment and within the manual.

The "Danger," "Warning," and "Caution" statements described in this manual are only supplementary precautions to all safety notices.

The Company shall not be held liable for equipment damage or property loss resulting from violation of safety operation requirements or safety standards of design, production, and use of equipment, including but not limited to the following:

- The installation environment does not comply with relevant international, national, or regional standards.
- Failure to comply with local laws and regulations during the transportation, installation, operation, and maintenance of the equipment.
- The installation area does not meet the requirements of the equipment.
- Cables, tools, and other materials used do not comply with relevant international, national, or regional standards.
- Damage caused by storage conditions that do not meet the requirements of the equipment.
- Failure to operate according to the instructions and precautions in the manual.
- Failure to follow the prescribed sequence of steps for installation, operation, and maintenance in the manual, unauthorized changes to the installation sequence, unauthorized modification, additions, or changes to equipment, etc.
- Failure to handle the equipment with care or violent installation may result in equipment damage and liquid leakage and pose a risk of fire or explosion hazards.
- Failure to follow the operational requirements indicated on warning labels on the equipment or tools.
- Negligence, improper operation, or deliberate damage.
- Damage caused during transportation by you or a third party you commission.
- Damage caused by the change of the scenarios for which the equipment is intended on the customer or a third party company side.
- Equipment damage caused by failure to use the accessories supplied with the packing box or purchase and use accessories of the same specification on the customer or a third-party company side.
- Equipment damage caused by unauthorized disassembly or replacement of the equipment or modification of software code, or other improper operations.
- Equipment damage caused by force majeure (such as war, earthquake, fire, storms, lightning, floods, and debris flow).

- Damage caused by the failure of the natural environment or external power parameters to meet the standard requirements for the normal operation of the equipment. For example, the actual operating temperature of the equipment is too high or too low.
- The equipment is stolen.
- The equipment is damaged after the warranty period expires.

1.2 Personnel Requirements

- Professionals or well-trained personnel must be assigned to install, operate, and maintain the equipment. During operations, irrelevant personnel are prohibited from approaching the work area.
 - Professionals: Personnel who are familiar with the composition and working principle of the system or equipment, have participated in training or operated the equipment, and are familiar with the factors that may lead to risks during the installation, operation, and maintenance of the equipment and risk levels.
 - Well-trained personnel: Personnel who have participated in relevant technical and safety training, have relevant experience, can identify operational risks, and can take relevant corrective measures to reduce the impact of risks.
- For special operations, such as climbing and electrical operations on high-voltage equipment, the operator must be certified for special operations as required by the local country/region.
- Only authorized professionals can replace the equipment or components (including software), remove safety devices, or repair the equipment.

1.3 Handling and Transportation Requirements

- Wear personal protective equipment such as protective gloves and safety shoes while handling the equipment.
- Select an appropriate handling method according to the equipment weight.
- When handling the equipment, always follow the package orientation marking. Do not turn the equipment upside down or tip it over.
- The tilt angle of the equipment with packaging must be less than or equal to 15°. After the equipment is unpacked, its tilt angle must be less than or equal to 10°. Take into account the heights of persons assigned to handle the equipment to ensure that the equipment is handled stably.
- Lift or move the equipment slowly to avoid personal injury.
- When using a forklift, position the forks so that the center of gravity of the equipment is aligned and secure the equipment as needed. Designate a person to keep an eye on the handling. Do not stand under the forks.
- Place the equipment according to the stack requirement indicated on the packaging.
- Ensure the equipment is placed on a flat and stable surface and do not tilt or place the equipment upside down.
- Transport the equipment with proper protective measures to avoid exposure to rain or water.

1.4 Storage Requirements

- The storage location must comply with local laws and regulations.
- Do not store the equipment without packaging. If the equipment has been unpacked and is not put into use immediately, please place it back into its original packaging with the desiccant retained and seal it with tape.
- Do not expose the equipment to direct sunlight, humidity, condensation, dirt, rain, or a flammable, explosive, or corrosive environment.
- Regularly check the equipment (recommended once every three months) during the storage period. Take measures to prevent pests and rodents in the storage area. Replace the packaging immediately if the packaging is damaged by pests or rodents.
- Store the equipment according to the storage requirements indicated on the packaging.
- When temporarily storing equipment outdoors, stacking on pallets is prohibited, and protective measures (such as providing tarpaulins, etc.) must be implemented to prevent the equipment from being exposed to rain, snow, standing water, or other corrosive elements.
- Regularly record the temperature, humidity, and other conditions of the storage environment during the storage period.
 - Storage temperature: -40°C to 70°C, with a recommended range of 20°C to 30°C.
 - Relative humidity: 0% RH to 95% RH.
- Follow the First-in First-out (FIFO) principle for shipment.
- If your equipment has been stored for more than 2 years, please go through professional inspection and testing before putting it into operation.

1.5 Operation Requirements

Danger

High Voltage and Hazards:

- Do not perform operations on the equipment with power on (including but not limited to installation, wiring, replacement). Before operation, please make sure all power supplies to the equipment have been disconnected, including but not limited to the grid side, inverter and diesel generator power switches. Operation with power on may lead to fire, electric shock, arcing, or explosion, resulting in personal injury or property loss.
- Do not power on the equipment before the installation or professional evaluation is complete.
- Do not operate the equipment in bad weather conditions, including but not limited to lightning, rain, snow, or typhoon.
- Do not expose the equipment to high temperatures or heat sources for an extended period of time, such as sunlight, ignition sources, or heaters.
- Do not clean or soak the equipment with water, alcohol, oil, or other liquids to avoid leakage current and electrical shock.
- Do not impact, drag, or step on the equipment. In case of accidental impact, stop using the equipment immediately and contact your sales representative. The equipment shall be subject to inspection and evaluation by professionals before being put into operation again.
- Before operating the equipment, check whether the equipment is damaged. For any abnormality, such as appearance deformation or odor, contact your sales representative instead of disassembling the equipment without authorization.
- If you find that the equipment works abnormally or that the equipment may cause personal injury, such as appearance deformation, odor, or arcing, stop your operation immediately, report the fact to the person in charge, and take effective measures.
- Wear personal protective equipment such as insulating gloves, insulating shoes, and safety hats while operating the equipment. Do not wear conductive accessories such as metal bracelets, rings, or necklaces.
- Use insulated tools when installing or wiring.
- Equipment that must be grounded is permanently connected to the PGND. Connect the PGND in the first step before connecting cables, and when replacing an equipment, remove the PGND in the last step.
- Do not touch terminals with bare hands or conductors or damp objects. Measure the voltage of the contact before touching a terminal to avoid the risk of electric shock.
- Prevent foreign objects from falling into the equipment while operating the equipment. Otherwise, the equipment may be short-circuited or damaged, or power supply to loads may be derated or power failure may occur, or this may even result in personal injury.
- Before powering off the 10 kV or higher medium-voltage equipment, it is recommended to turn off the inverter and switch off the low-voltage equipment first.
- Touch up paint scratches on the surface of the equipment.

Warning

- Do not disable any protective devices, including but not limited to protective covers and surge arresters.
- Do not touch the hot surface in the heat dissipation area when the equipment is operating.
- Do not cover the heat dissipation area, and maintain a 300 mm to 600 mm channel for heat dissipation to prevent high temperatures from causing a fire when the equipment is operating.

Caution

- You must obtain a license for power utilities in the country or region where the equipment is located before the equipment can be connected to the grid.
- Do not use damaged or unqualified cables or tools. Before operating the equipment, ensure that all cables and tools comply with the requirements, and keep records. Upon completion of operation, make an inventory and recover the cables and tools in full to prevent them from being left in the equipment to avoid safety hazards.
- Comply with the power station safety regulations of the country or region where the equipment is located when operating the equipment, including but not limited to operation tickets and work tickets.
- Carbon dioxide fire extinguishers or ABC dry powder fire extinguishers are recommended.
- Keep irrelevant personnel away from the operation site. Please install a temporary fence or set a warning line around the operation site, and attach "No Entry for Irrelevant Personnel" and other signs.
- Do not cover or damage the warning label or nameplate on the equipment. Replace the warning label or nameplate if it is damaged or cannot be clearly recognized due to long-term use.
- Before operating or maintaining the equipment, check whether there is water, snow, or other debris on the top of the equipment. Clean it up when necessary.

Do not use the equipment in the following situations:

- When connected to public infrastructure systems, such as traffic lights or security systems.
- When connected to emergency medical equipment.
- When connected to elevators and other control devices.
- Any other critical systems.

1.5.1 Equipment Installation

Warning

- Before installing the equipment, check whether the screws installed before delivery are secured. Before delivery, the tightened screws are marked with lines. If the marks are misaligned, the screws are loose. Tighten the screws again.

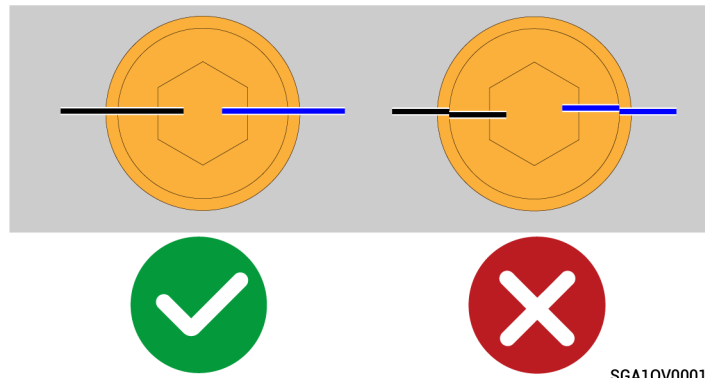

SGA10V00019

- Get well prepared for the bearing load when handling the equipment to prevent it from falling and causing injury.

Ladder Safety

- Do not use ladders if you are not well-trained or instructed.
- Do not use unqualified ladders, including but not limited to damaged, broken, deformed, or temporary ladders.
- Do not use a ladder that does not meet the load-bearing requirements.
- Use wooden or fiberglass ladders when you climb up for electrical operations.
- A straight ladder must be set at a gradient of 60° to 70°.
- Do not throw objects from heights when operating on a ladder.
- We recommend that you designate a person to monitor when operating on a ladder.
- Lock the door when using a ladder at the entrance of the passageway.

Drilling Safety

- Do not drill holes on the equipment.
- Wear safety goggles and protective gloves when drilling holes.
- Do not place the equipment near drilling positions to prevent debris from falling into the equipment.
- Clean up any debris promptly after drilling.

1.5.2 Cable Connections

Danger

- Before connecting cables, ensure that the equipment is not damaged. Otherwise, electric shock or fire hazard may occur.
- Before connecting or removing cables, ensure that the upstream and downstream switches of the equipment and the switches on the equipment are turned off.
- Do not intertwine cables or route cables across each other. It is recommended that cables be bundled by category.
- Do not route cables through the air inlet and air outlet of the equipment.
- Do not use cables with damaged insulation. No sharp edges or burrs are allowed in cable holes. Replace cables with insufficient length. Do not extend cables using welding or similar methods.
- The ground impedance of the equipment should meet national and regional standards.
- Verify the cable selection by referring to IEC-60364-5-52 or local laws and regulations if there are changes in cabling methods or environmental conditions such as temperature and humidity.
- Keep cables at least 100 mm away from the heat source to prevent cable aging at high temperatures.
- The lower the ambient temperature is, the more brittle the cable plastic sheath becomes. To prevent sheath cracking during installation, install cables at temperatures above 0°C and handle them with caution when transporting. If cables have been stored in an environment below 0°C for an extended period of time, move cables to an environment above 0°C for at least 24 hours before using again.
- Before installing cables, ensure that cables are properly labeled, insulated, and identified. Connect cables correctly and completely according to the labels and installation instructions.
- For underground cabling, fix cables with cable trays and clips. Before backfilling, reserve a proper cable length to ensure that cables are tightly fitted against the ground in the backfilling area. Otherwise, terminals may be deformed, damaged, or loosened due to stress on cables.

1.5.3 Requirements for High-altitude Work

- High-altitude operations must comply with local high-altitude operation regulations.
- Personnel working at heights shall strictly adhere to high-altitude safety regulations. The company shall not be responsible for accidents caused by violations of high-altitude safety operation rules.
- Any work conducted at a height of more than 2 meters above the ground is considered high-altitude work.
- High-altitude work is prohibited under any of the following conditions: wet steel pipes due to rain, or other potentially hazardous situations.
- Before high-altitude work, carefully inspect climbing tools and safety equipment, such as safety helmets, safety belts, ladders, springboards, scaffolding, lifting equipment, etc. If any items do not meet requirements, immediate improvements must be made or high-altitude work should be refused.
- At high-altitude work sites, dangerous restricted areas shall be demarcated with clear signs, and unauthorized personnel are strictly prohibited from entering.
- Guardrails and signs shall be installed at edges and openings of high-altitude work areas to prevent accidental falls.
- The ground below high-altitude work areas must not have scaffolding, springboards, or other debris piled up. Ground personnel are strictly prohibited from staying or passing directly below high-altitude work areas.
- Simultaneous work on upper and lower levels should be avoided whenever possible. If unavoidable, dedicated protective sheds or other protective measures must be set up between levels, and tools, materials, or other debris are strictly prohibited on upper levels.
- Implement proper safety precautions by wearing hard hats, safety harnesses or waist ropes, which must be secured to sturdy structural components. It is strictly prohibited to attach them to movable/unstable objects or metal with sharp edges to prevent hook slippage and falling accidents.
- Carry operating equipment and tools properly to prevent tool drops that may injure others.
- It is strictly forbidden for aerial workers to throw objects from heights to the ground or vice versa. Objects should be transported using strong ropes, baskets, aerial work platforms or cranes.
- Horseplay is strictly prohibited during aerial work, and resting in aerial work zones is forbidden.
- After completing aerial work, all elevated work tools, safety equipment, protective gear and other debris must be cleared or removed from the site, restoring the area to its original condition.

1.5.4 Equipment Maintenance and Replacement

- Before maintaining or replacing the equipment, power off and wait for the delay time as instructed on the label on the equipment before operation.
- When maintaining the power equipment or power distribution equipment at the downstream direction of the power supply equipment, turn off the output switch of the power supply equipment.
- When maintaining the power distribution equipment or power equipment at the downstream direction of the power supply equipment, turn off the output switch of the power supply equipment. To maintain a load, disconnect the load from the power switch.
- During equipment maintenance, attach labels, for example, "Do Not Turn On", on the upstream and downstream switches or circuit breakers and set warning signs to prevent accidental reconnection. Power up and put the equipment back into operation only after trouble is eliminated, or replacement is complete.
- Damaged cables, if any, should be replaced by professionals.

Chapter 2 Product Introduction

2.1 Functions and Designation

Functions

The product can be used in industrial and commercial PV storage and pure storage applications for data collection and monitoring, switchover between off-grid and backup power, diesel generator control, and energy management. The product must be used in conjunction with our battery packs and inverters.

- The Gateway provides backup power for the whole house or part of the loads. In the event of a grid power outage, the inverter seamlessly switches to the off-grid mode, and this switchover is insensible to backup loads.
- The Gateway can be connected to a diesel generator for an extended period of power supply in off-grid mode, and PV storage and diesel generator mode can be switched seamlessly.

Model description

This document covers the following product models:

S/N	models
1	Sigen Gateway TPLV C30-2
2	Sigen Gateway C60-2
3	Sigen Gateway C60 AU
4	Sigen Gateway TPLV C70-6
5	Sigen Gateway C120-6
6	Sigen Gateway C180-9
7	Sigen Gateway C300-12
8	Sigen Gateway C600
9	Sigen Gateway C1200
10	Sigen Gateway C600-B
11	Sigen Gateway C1200-B

Sigen Gateway TPLV C30-2



SGA10V00020

No.	Definition	Description
1	Brand	Sigen

No.	Definition	Description
2	Product series	Gateway
3	Grid type	TPLV: Three-phase Low Voltage
4	Application scenario	C: industrial and commercial scenario
5	Maximum power on grid side	<ul style="list-style-type: none"> ● 30: 30 kW ● 120: 120 kW ● 300: 300 kW ● 600: 600 kW ● 1200: 1200 kW
6	Number of supported inverters	<ul style="list-style-type: none"> ● 2: 2 units ● 6: 6 units ● 9: 9 units ● 12: 12 units

2.2 Product Appearance Introduction

2.2.1 Sigen Gateway TPLV C30-2

Dimensions

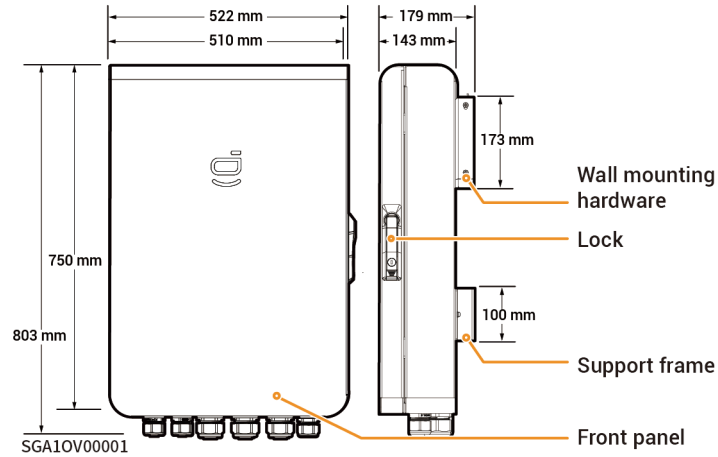

Bottom View

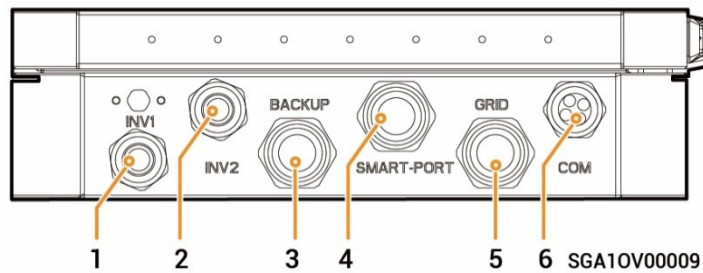

No.	Marking	Name
1	INV1	Wire-in port of inverter 1
2	INV2	Wire-in port of inverter 2
3	BACKUP	Wire-in port of backup loads
4	SMART-PORT	Wire-in port for smart loads/diesel generator
5	GRID	Wire-in port of power grid
6	COM	Wire-in port of communication

Interior View

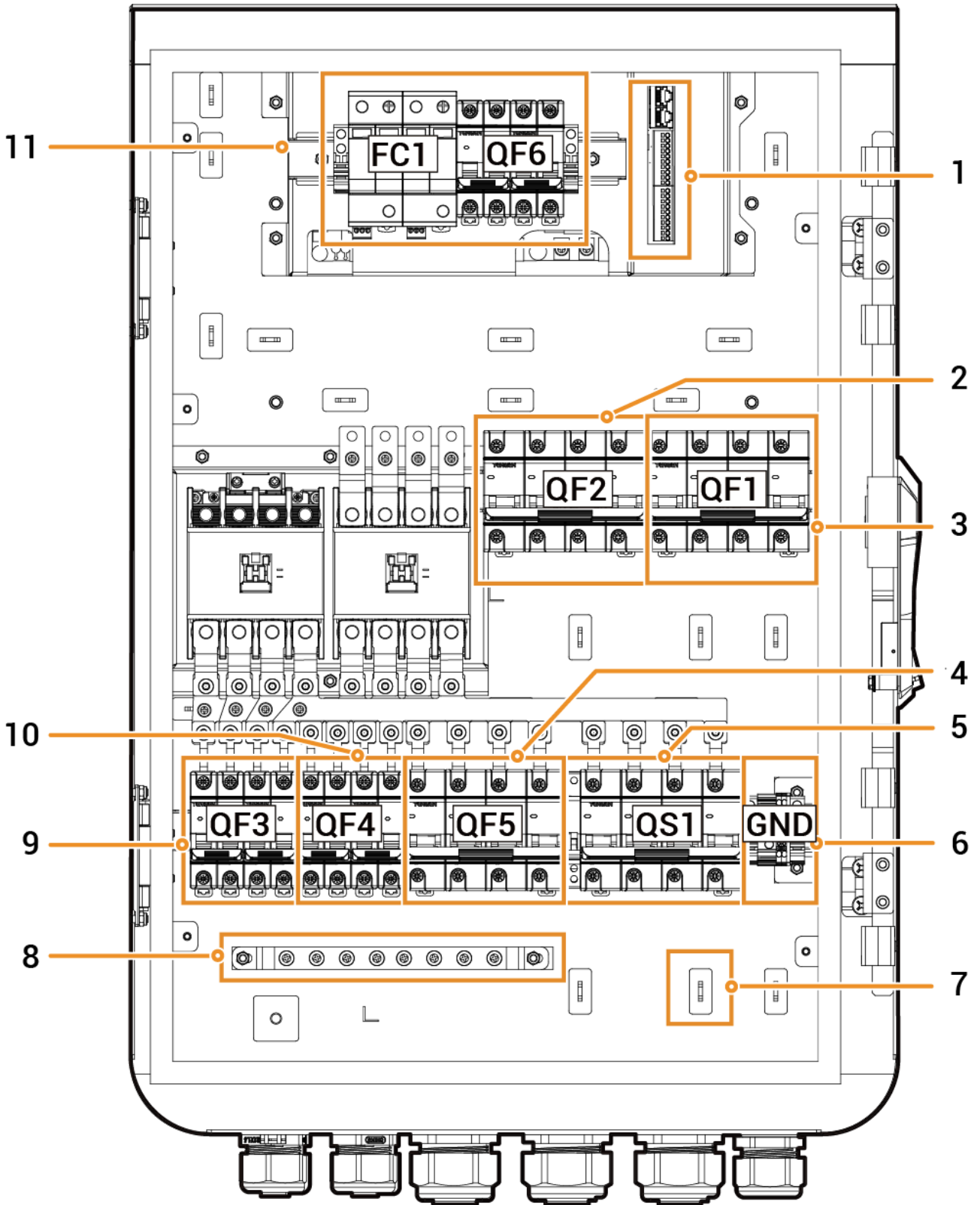

SGA10V00028

No.	Label	Name
1	-	RS485, DI, and DO interfaces
2	QF2	Miniature circuit breaker (Diesel generator)
3	QF1	Miniature circuit breaker (Power grid)
4	QF5	Miniature circuit breaker (backup loads)
5	QS1	Bypass switch
6	GND	GND
7	-	Cable clamp
8	-	Earthing bar
9	QF3	Miniature circuit breaker (Inverters 1)
10	QF4	Miniature circuit breaker (Inverters 2)
11	FC1+QF6	Miniature circuit breaker + Surge protection device

2.2.2 Sigen Gateway C60-2

Dimensions

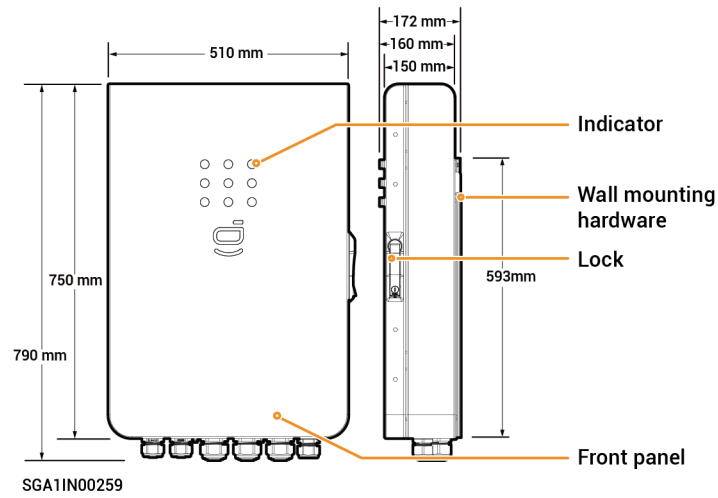

Bottom View

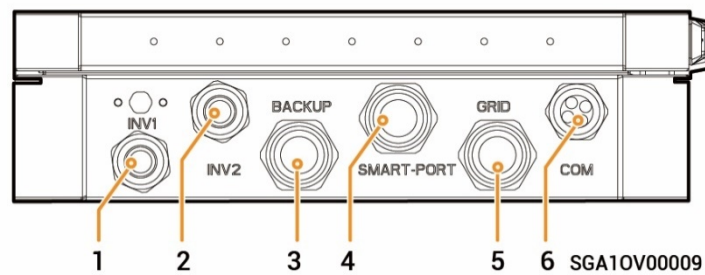

No.	Marking	Name
1	INV1	Wire-in port of inverter 1
2	INV2	Wire-in port of inverter 2
3	BACKUP	Wire-in port of backup loads
4	SMART-PORT	Wire-in port for smart loads / generator
5	GRID	Wire-in port of power grid
6	COM	Wire-in port of communication

Interior View

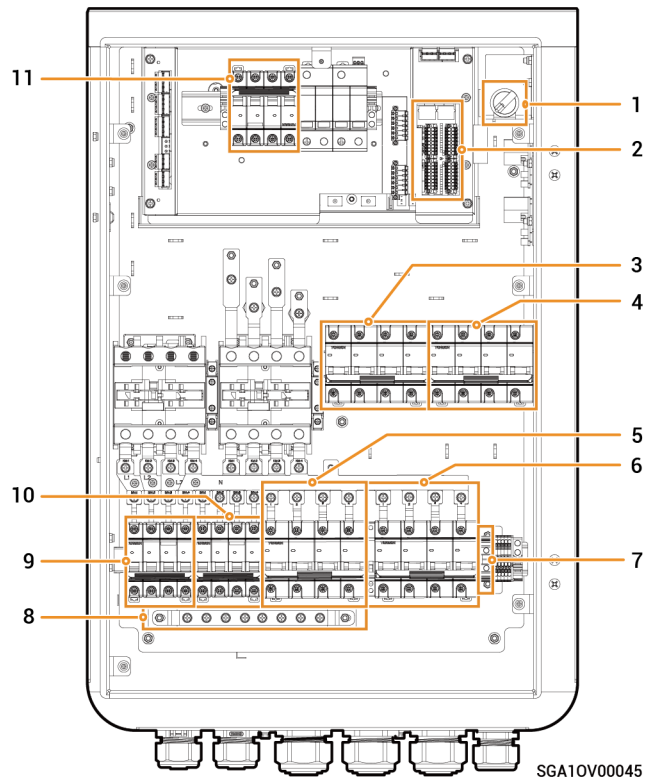

SGA10V00045

No.	Label	Name
1	Q1	LED switch
2	-	Communication terminal (connecting to FE, DI, DI communication cable)
3	QF2	Miniature circuit breaker (connecting to Smart loads[1]/Generator)
4	QF1	Miniature circuit breaker (connecting to Power grid)
5	QF5	Miniature circuit breaker (connecting to Backup loads)
6	QS1	Bypass switch
7	GND	GND terminal
8	PE	Grounding copper busbar
9	QF3	Miniature circuit breaker (connecting to Inverters 1)
10	QF4	Miniature circuit breaker (connecting to Inverters 2)
11	QF6	Surge protection device

Note [1]:

- All the power equipment in the owner's home can be connected as smart loads.
- To ensure that this product maximizes the benefits to users, it is recommended that the high-power equipment be connected as smart loads (third-party inverter, heat pumps, pool heaters, clothes dryers, immersion heaters, etc.), which can be cut off when the energy storage system has low power. Other low-power equipment are connected as household loads (lights, routers, etc.).

2.2.3 Sigen Gateway C60 AU

Dimensions

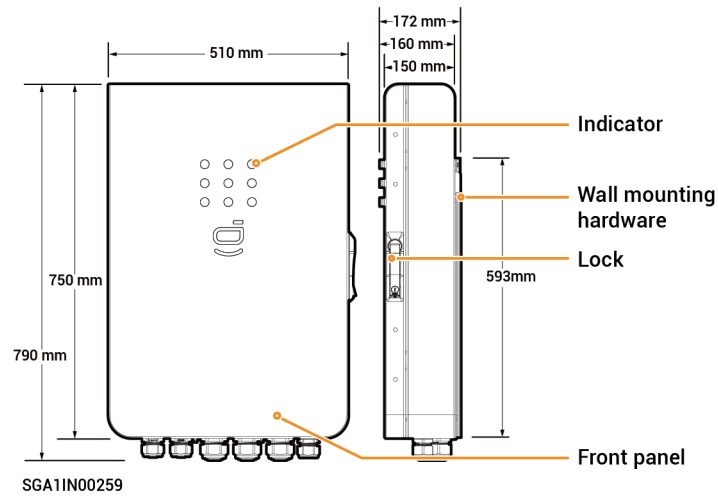

Bottom View

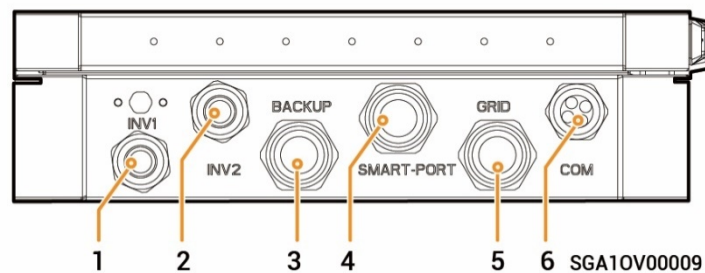

No.	Marking	Name
1	INV1	Wire-in port of inverter 1
2	INV2	Wire-in port of inverter 2
3	BACKUP	Wire-in port of backup loads
4	SMART-PORT	Wire-in port for smart loads / generator
5	GRID	Wire-in port of power grid
6	COM	Wire-in port of communication

Interior View

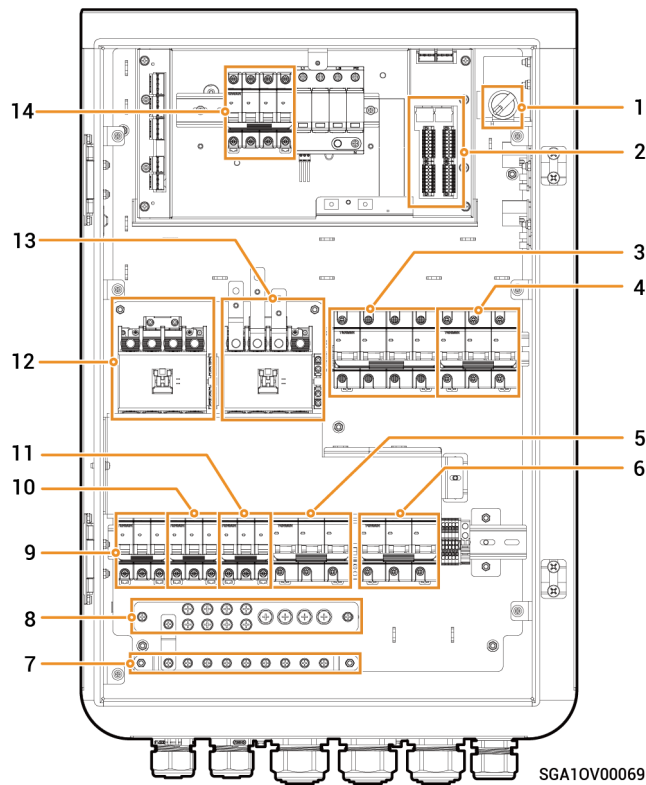

No.	Label	Name
1	Q1	LED switch
2	-	Communication terminal (connecting to FE, DI, DI communication cable)
3	QF2	Miniature circuit breaker (connecting to Smart loads[1]/Generator)
4	QF1	Miniature circuit breaker (connecting to Power grid)
5	QF6	Miniature circuit breaker (connecting to Backup loads)
6	QS1	Bypass switch
7	PE	Grounding copper busbar
8	N	N-line copper busbar
9	QF3	Miniature circuit breaker (connecting to Inverters 1, maximum support 30 kW)

No.	Label	Name
10	QF4	Miniature circuit breaker (connecting to Inverters 2, maximum support 30 kW)
11	QF5	Miniature circuit breaker (connecting to Inverters 3, maximum support 20 kW)
12	KM2	Smart loads/Generator contactor
13	KM1	Grid contactor
14	QF7	Surge protection device

Note [1]:

- All the power equipment in the owner's home can be connected as smart loads.
- To ensure that this product maximizes the benefits to users, it is recommended that the high-power equipment be connected as smart loads (third-party inverter, heat pumps, pool heaters, clothes dryers, immersion heaters, etc.), which can be cut off when the energy storage system has low power. Other low-power equipment are connected as household loads (lights, routers, etc.).

2.2.4 Sigen Gateway C120-6, TPLV C70-6)

Dimension Drawing

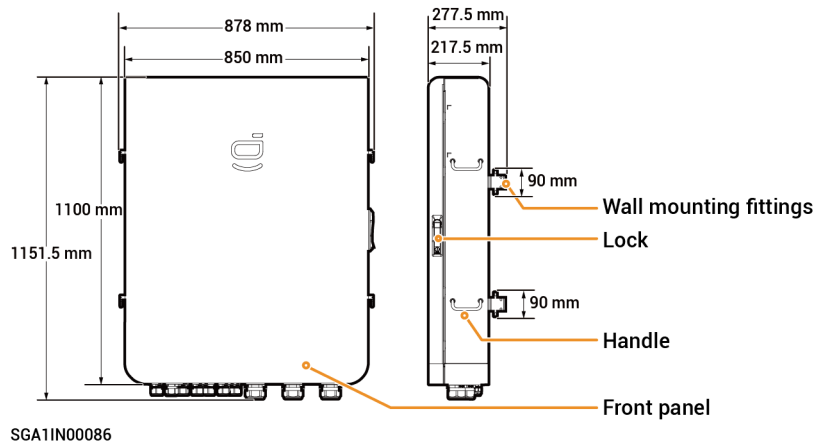

Bottom View

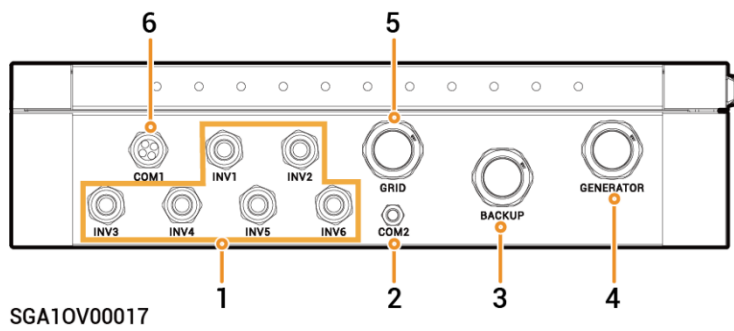

Serial number	Name	Silkscreen
1	Inverter wiring hole	INV1~INV6
2	(Reserved) Communication line wiring hole	COM2
3	Backup power load wiring hole	BACKUP
4	Diesel generator wiring hole	GENERATOR
5	Grid wiring hole	GRID
6	FE, DI, DO communication wiring hole	COM1

Internal View

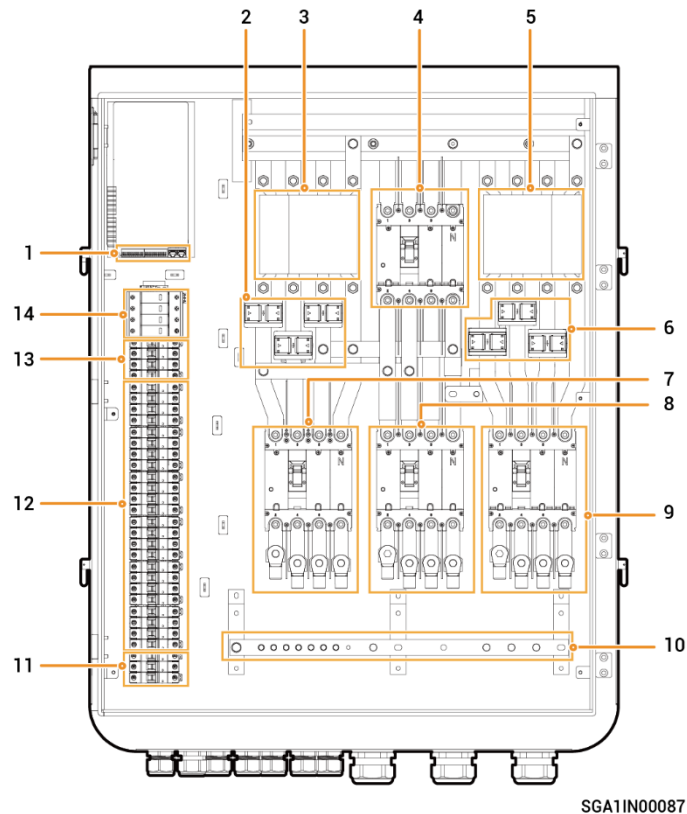

SGA1IN00087

Serial number	Label	Name
1	-	FE, DI, DO and other interfaces
2	-	Grid current transformer
3	KM1	Grid-side contactor
4	QS1	Bypass switch
5	KM2	Diesel generator contactor
6	-	Diesel generator current transformer
7	QF1	Molded case circuit breaker (connected to grid)
8	QF3	Molded case circuit breaker (connected to backup load)
9	QF2	Molded case circuit breaker (connected to diesel generator)
10	-	Grounding copper busbar
11	QF11	(Reserved) Molded Case Circuit Breaker
12	QF5~QF10	Molded Case Circuit Breaker (connected to inverter)
13	QF4	Surge Protector Switch
14	FC1	Surge Protector

2.2.5 Sigen Gateway (C180-9, C300-12)

Dimension Drawing

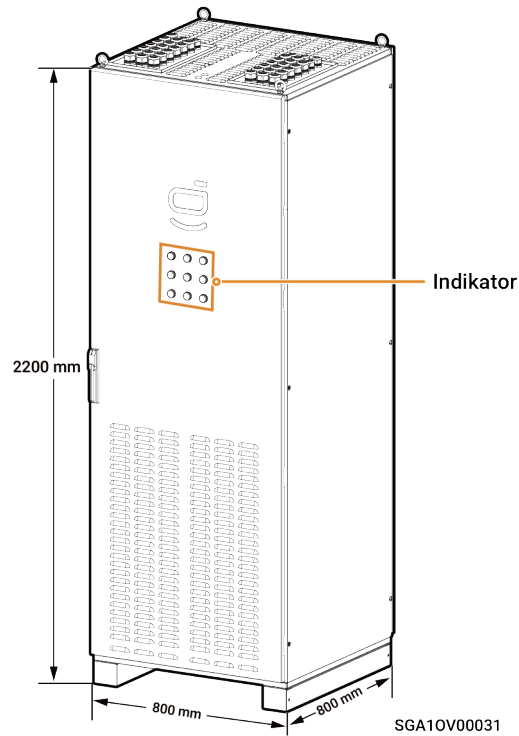

Bottom View

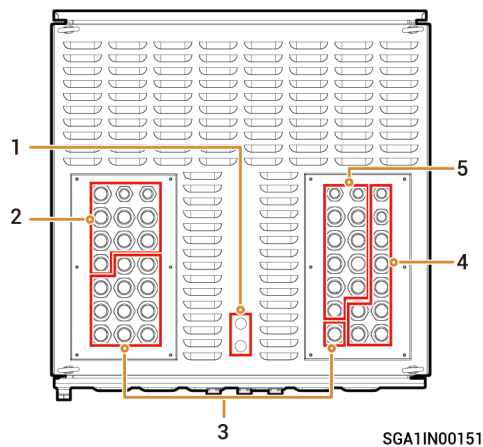

Serial number	Name	Silkscreen
1	Signal wire routing hole	INV1~INV6
2	Load AC wire routing hole	COM2
3	Inverter AC wire routing hole	BACKUP
4	Generator AC cable routing hole	GENERATOR
5	Grid AC cable routing hole	GRID

Internal View

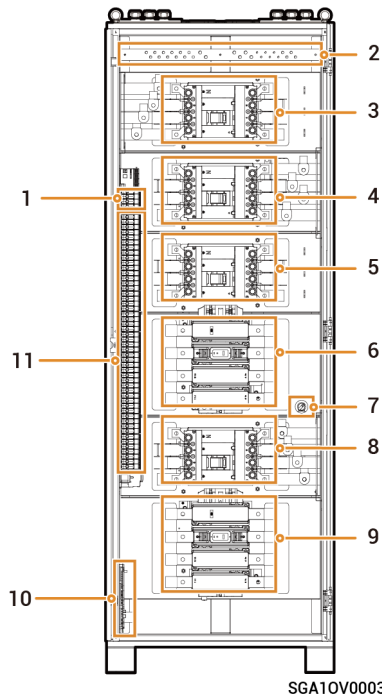

No.	Label	Name
1	QF4	Surge protector switch
2	-	Grounding bar (connected to PE wire)
3	QF3	Load switch (connected to load)
4	QF1	Grid-side switch (connected to power grid)
5	QS1	Bypass switch
6	KM1	Grid-side contactor
7	-	Indicator light switch (controls indicator power supply)
8	QF2	Generator switch (connected to generator)
9	KM2	Generator contactor
10	-	Signal port
11	QF5~QF16	Miniature circuit breaker (connected to inverter)

2.2.6 Sigen Gateway (C600, C1200, C600-B, C1200-B)

Dimensions

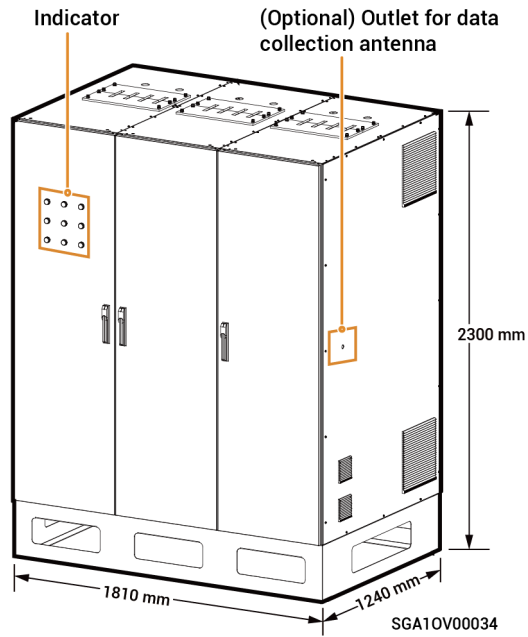

Port Description

Top view

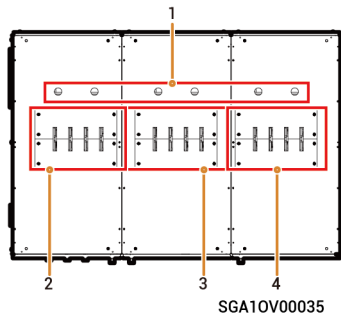

C600/C1200 Bottom View

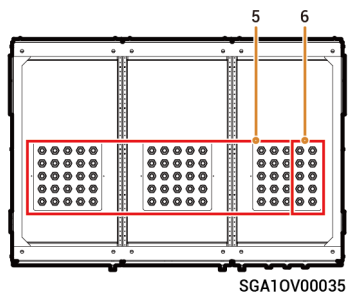

C600-B/1200-B Bottom View

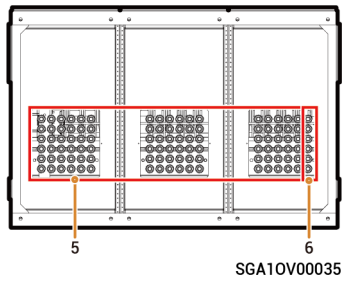

No.	Name
1	Routing hole for PE cable
2	Copper busbar entry (grid AC cable)
3	Copper busbar entry (smart loads/generator AC cable)
4	Copper busbar entry (load AC cable)
5	Routing hole for AC cable of the inverter
6	Routing hole for signal cable

C600/C1200 only has one difference in the number of miniature circuit breakers in the structure, this manual takes C1200 as an example.

C1200/1200-B Interior View

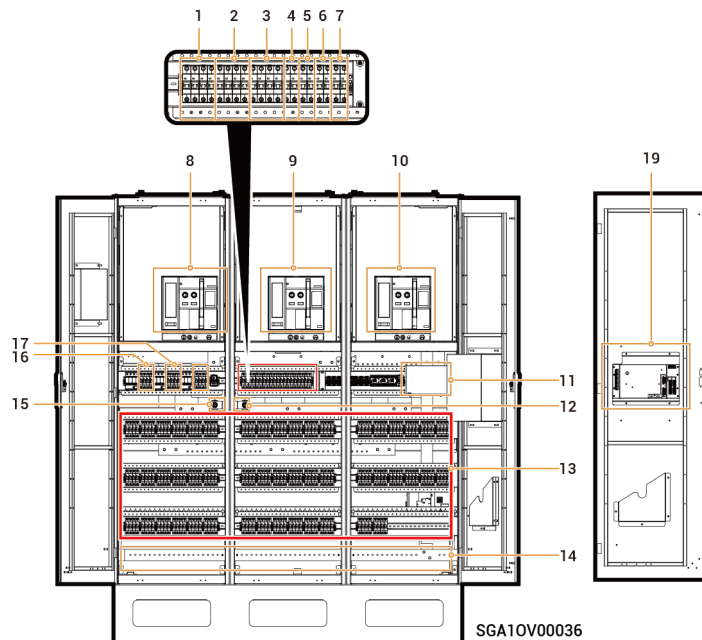

No.	Label	Name
1	1QF1	PCB board secondary control switch (connected to the power grid, and power supply switch for indicators)
2	1QF3	PCB board secondary control switch (connected to smart loads[1]/generator, and power supply switch for indicators)
3	1QF5	PCB board secondary control switch (connected to a load, and power supply switch for indicators)
4	1QF7	Secondary control switch of frame circuit breaker (connected to the power grid)
5	1QF8	Secondary control switch of frame circuit breaker (connected to smart loads/generator)
6	1QF9	Secondary control switch of frame circuit breaker (connected to a load)
7	1QF10	Secondary control switch (connected to a fan and a UPS)
8	QA1	Frame circuit breaker[1] (connected to the power grid)
9	QA2	Frame circuit breaker (connected to smart loads[2]/generator)
10	QA3	Frame circuit breaker (connected to a load)
11	SC	Mounting location of data collector
12	SA2	Bypass transfer switch (connected to smart loads/generator)
13	2QF1~2QF30 (C600)	Miniature circuit breaker (a gateway C600 contains 30 miniature circuit breakers, connected to an inverter)

No.	Label	Name
13	2QF1~2QF50 (C1200)	Miniature circuit breaker (a gateway C1200 contains 50 miniature circuit breakers, connected to an inverter)
14	PE	Grounding busbar (connects to the PE cable)
15	SA1	Bypass transfer switch (connected to the power grid)
16	1QF2	Surge arrester switch (connected to the power grid)
17	1QF4	Surge arrester switch (connected to smart loads/generator)
18	1QF6	Surge arrester switch (connected to a load)
19	-	Single-pole control box

C600-B/C1200-B only has one difference in the number of miniature circuit breakers in the structure, this manual takes C1200-B as an example.

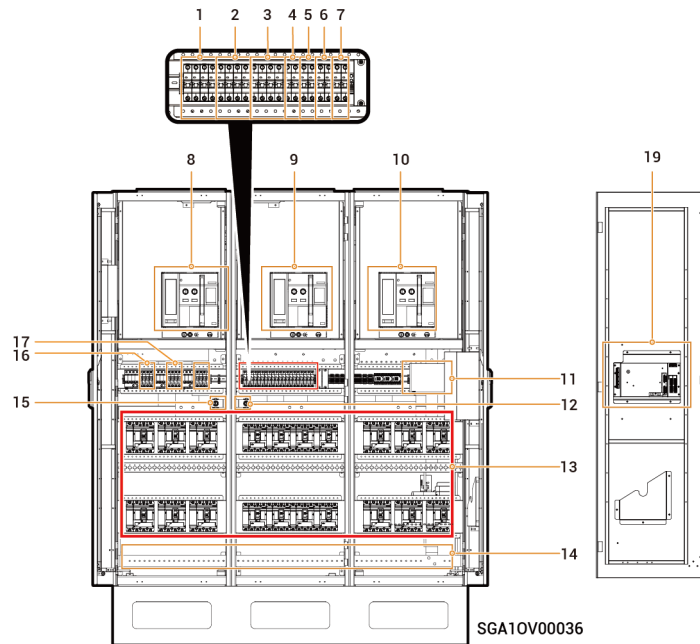

No.	Label	Name
1.	1QF1	PCB board secondary control switch (connected to the power grid, and power supply switch for indicators)

No.	Label	Name
2.	1QF3	PCB board secondary control switch (connected to smart loads ^[1] /generator, and power supply switch for indicators)
3.	1QF5	PCB board secondary control switch (connected to a load, and power supply switch for indicators)
4.	1QF7	Secondary control switch of frame circuit breaker (connected to the power grid)
5.	1QF8	Secondary control switch of frame circuit breaker (connected to smart loads/generator)
6.	1QF9	Secondary control switch of frame circuit breaker (connected to a load)
7.	1QF10	Secondary control switch (connected to a fan and a UPS)
8.	QA1	Frame circuit breaker ^[1] (connected to the power grid)
9.	QA2	Frame circuit breaker (connected to smart loads ^[2] /generator)
10.	QA3	Frame circuit breaker (connected to a load)
11.	SC	Mounting location of data collector
12.	SA2	Bypass transfer switch (connected to smart loads/generator)
13.	2QF1~2QF10 (C600-B)	Molded case circuit breaker(a gateway C600-B contains 10 molded case circuit breakers, connected to an inverter)
13.	2QF1~2QF20 (C1200-B)	Molded case circuit breaker(a gateway C1200-B contains 20 molded case circuit breakers, connected to an inverter)
14.	PE	Grounding busbar (connects to the PE cable)

No.	Label	Name
15.	SA1	Bypass transfer switch (connected to the power grid)
16.	1QF2	Surge arrester switch (connected to the power grid)
17.	1QF4	Surge arrester switch (connected to smart loads/generator)
18.	1QF6	Surge arrester switch (connected to a load)
19.	-	Single-pole control box





Note [1]:

The setting value of circuit breaker must be adjusted on site according to the actual situation. For more information about the setting value, see Installation Guide for Corresponding Models, and for the operation method, see the Instruction Manual for Circuit Breaker.

Note [2]:

- All the power equipment in the owner's home can be connected as smart loads.
- To ensure that this product maximizes the benefits to users, it is recommended that the high-power equipment be connected as smart loads (heat pumps, third-party inverter, etc.), which can be cut off when the energy storage system has low power.

2.3 Label Description

Symbol	Definition
	Warning! Danger! Electrical discharge AC voltage is present on the cover of the equipment. Please take protective measures before operating the equipment.
	After the equipment is powered off, internal components discharge in a delay time. Wait for the duration according to the delay time on the label until the equipment is fully discharged.
	Warning! Danger! Hot The surface of the equipment is hot when the equipment is operating. Do not touch it to avoid burns.
	Operate the equipment by referring to the User Manual.
	GND symbol

2.4 Supported Power Supply Methods for the Power Grid

- The grid supply methods supported include TN-S, TN-C-S, and TT.
- When TT is used as the power supply technique for the power grid, the voltage between N and PE is required to be < 30 V.

Gateway Single-phase Series Products:

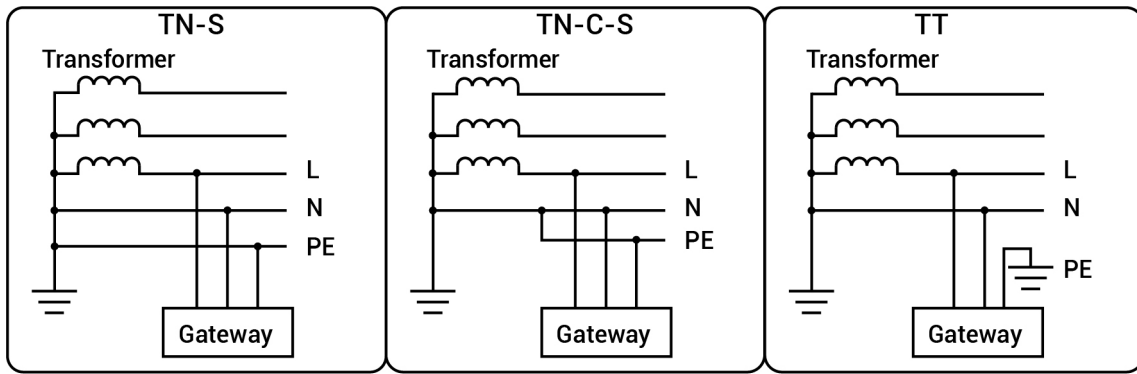

SVA10V00011

Gateway three-phase series products:

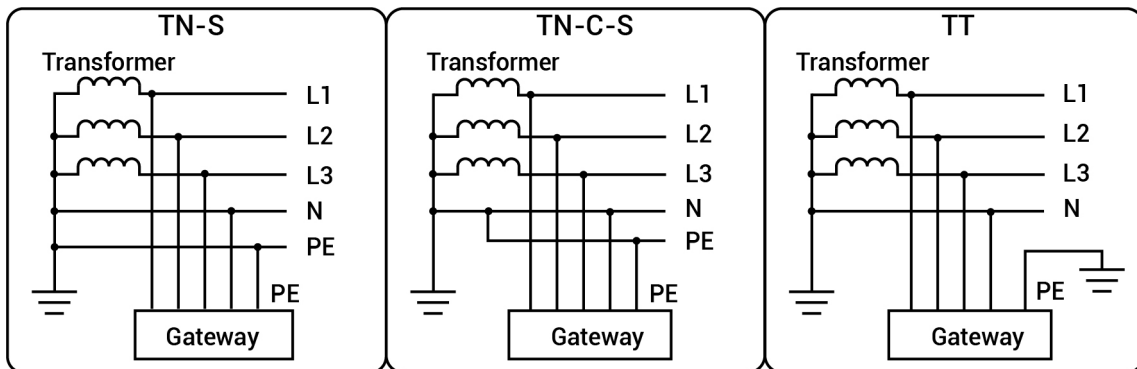

SVA10V00010

2.5 Introduction to system wiring

- This product is applicable to household backup power system networking scenarios. It must be used in conjunction with PV panels, inverters, battery packs, main control switches, loads, generators, and power grid.
- In the event of a power outage, the household energy storage system switches to off-grid operation mode. After the power grid resumes normal operation, the household energy storage system switches back to on-grid mode. This achieves a seamless switchover between PV storage and Generator.

Tips

- Under backup power networking, the duration of off-grid operation of the backup power load is related to the power supply capacity of the PV storage system. If there is an abnormality in the power supply of the PV storage system during off-grid operation (including but not limited to abnormal PV power generation, insufficient battery power, and abnormal power supplies to the Generator), the backup power load will still be unable to operate.
- The networking diagram takes two inverters as an example. The number of inverters that can be connected depends on the Gateway specification. For more information, see Table 2-1.

Table 2-1

S/N	Model	Number of Inverters that can be connected
1	Sigen Gateway TPLV C30-2	2 units
2	Sigen Gateway C60-2	2 units
3	Sigen Gateway C60 AU	2 units
4	Sigen Gateway TPLV C70-6	6 units
5	Sigen Gateway C120-6	6 units
6	Sigen Gateway C180-9	9 units
7	Sigen Gateway C300-12	12 units
8	Sigen Gateway C600	30 units
9	Sigen Gateway C1200	50 units
10	Sigen Gateway C600-B	10 units
11	Sigen Gateway C1200-B	20 units

Whole home backup system wiring diagram

Single inverter (Gateway has the circuit breaker for connecting smart load/diesel generator)

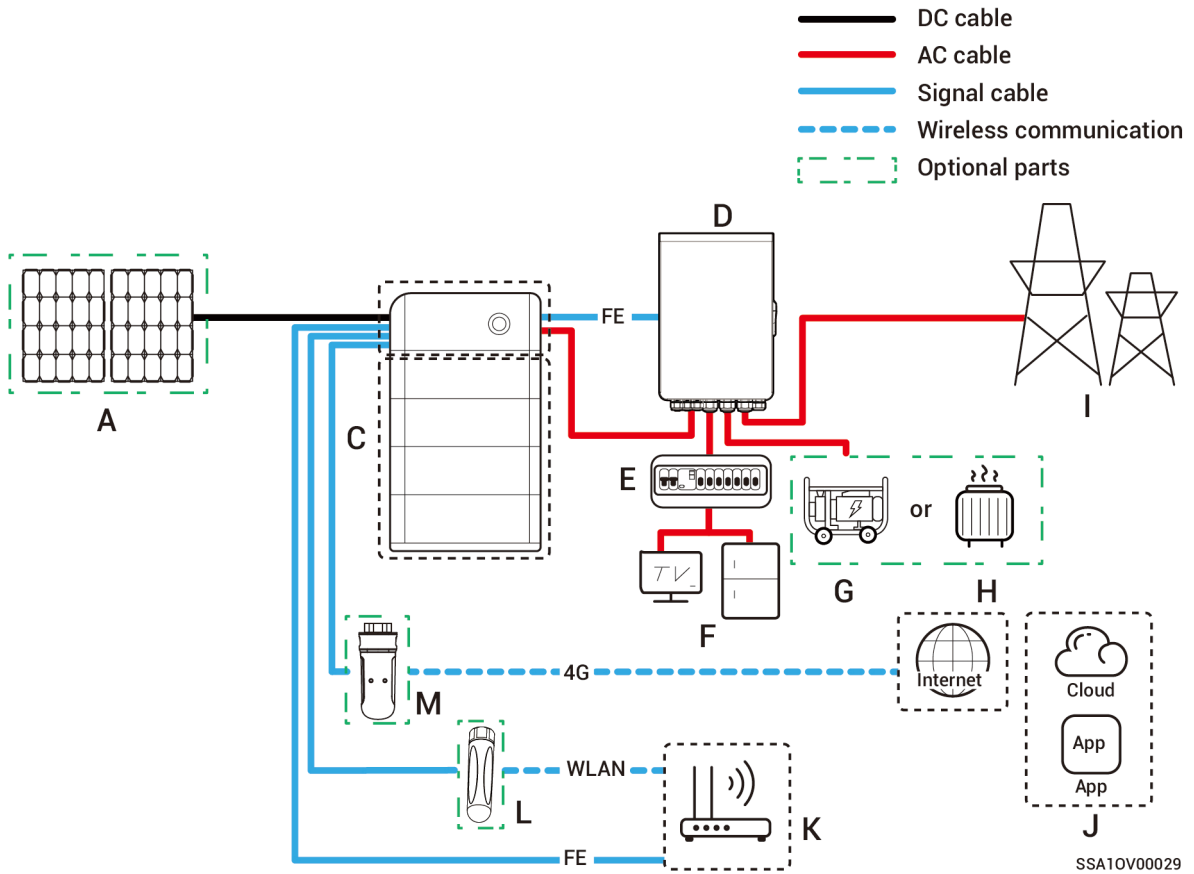

Single inverter (Gateway does not have the circuit breaker connected to the smart load/diesel generator)

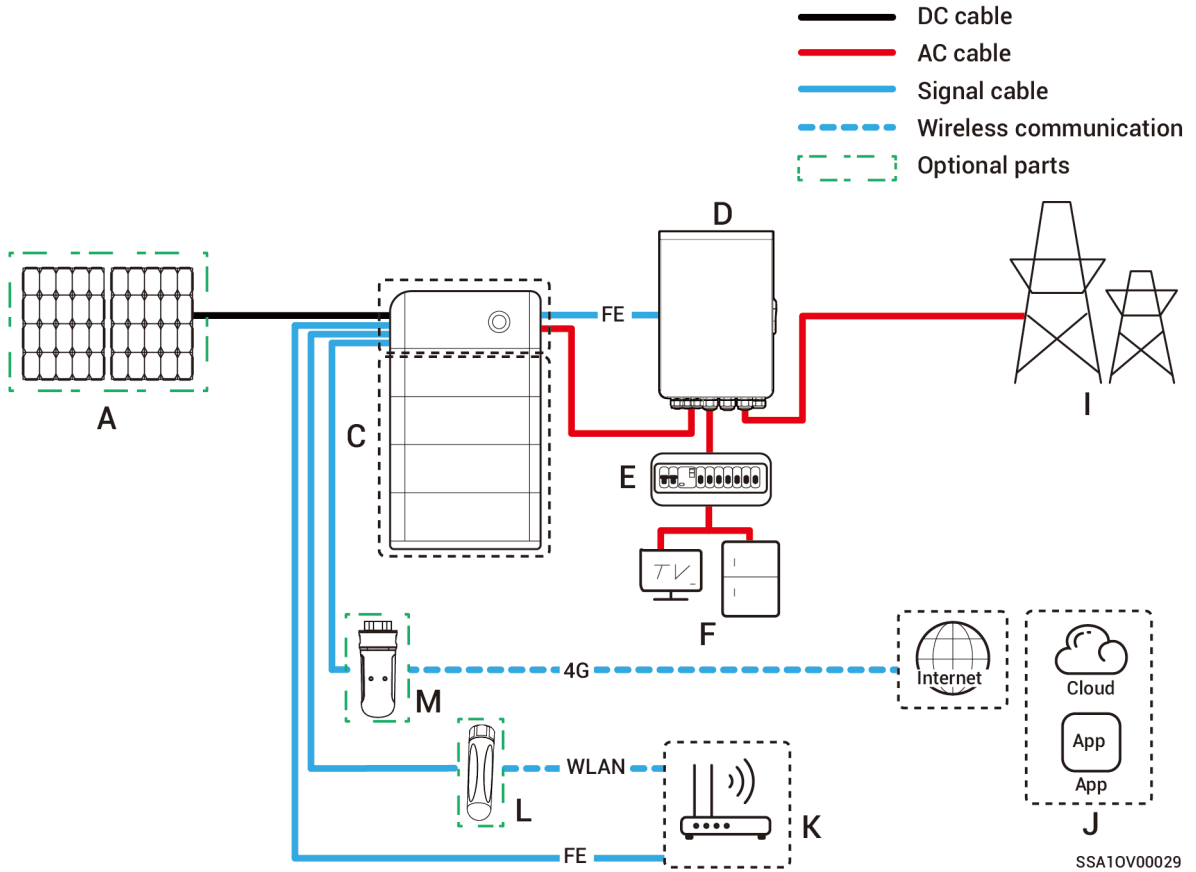

SSA10V00029

Multiple inverters (Gateway has the circuit breaker for connecting smart load/diesel generator)

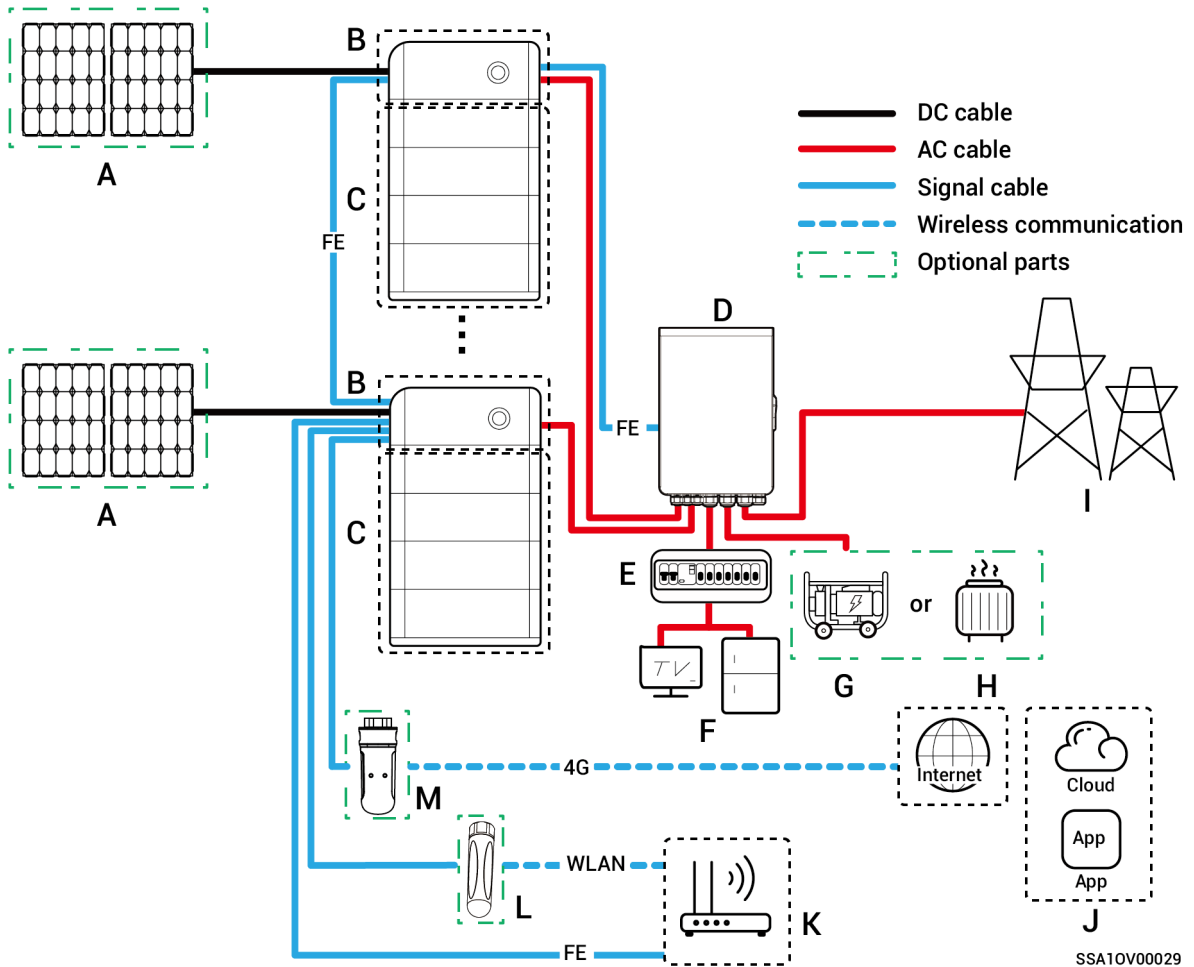

Multiple inverters (Gateway does not have the circuit breaker connected to the smart load/diesel generator)

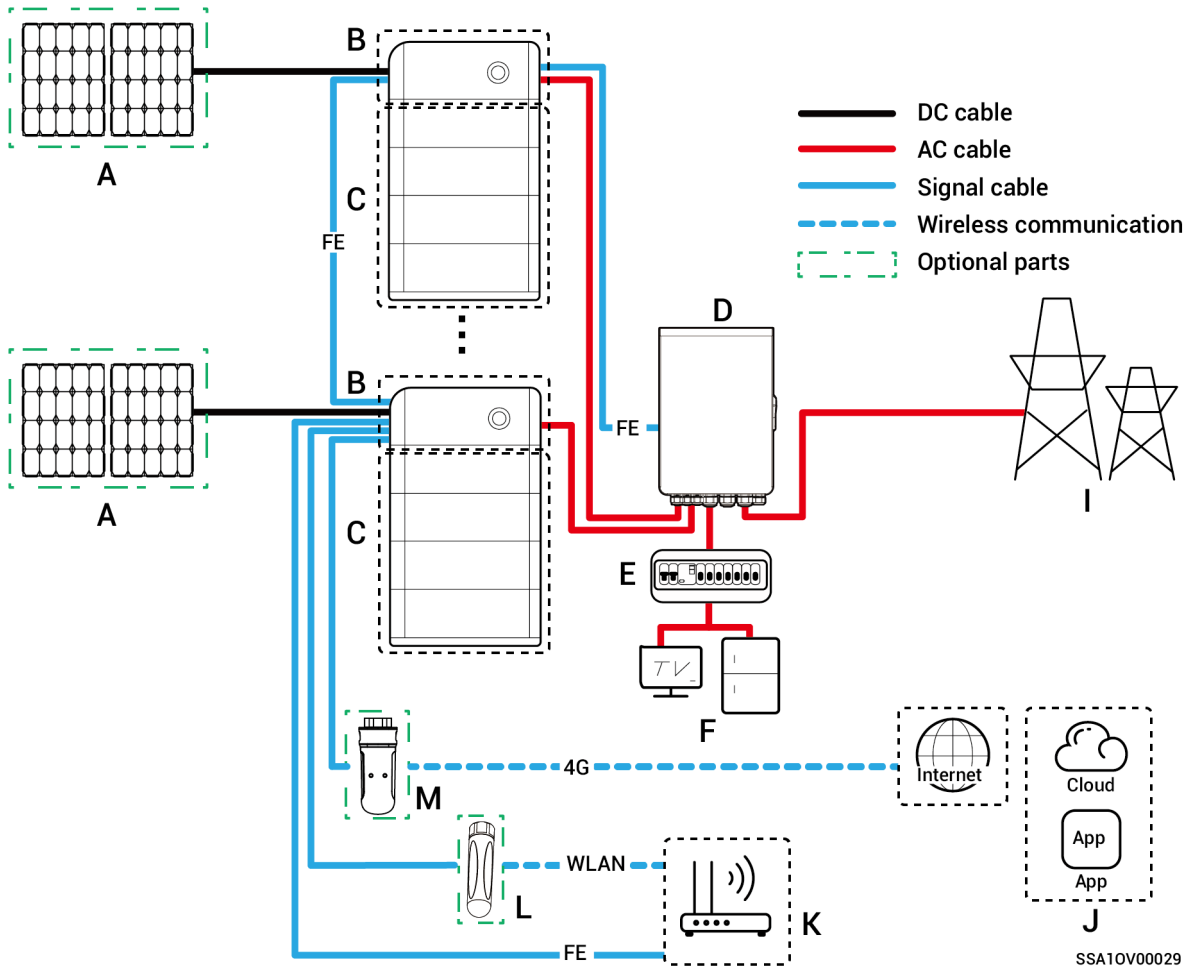

No.	Description	No.	Description	No.	Description
A	PV panel	B	SigenStor EC/ Sigen Hybrid	C	SigenStor BAT
D	Gateway	E	Backup Distri- bution panel	F	Backup House- hold loads
G	Diesel generator	H	Smart loads	I	Power grid
J	mySigen	K	Router	L	Antenna
M	CommMod				

Tips

- If F (backup household load) experiences leakage, it may pose a risk of electric shock. In order to avoid this hazard, a residual current device (RCD) must be installed between the D (Gateway) and the F (backup household load).

Tips

- As a backup energy source for long-term off-grid applications, the diesel generator can work in tandem with the Gateway to provide a smooth transition between PV, storage and diesel generation.
- All the power equipment in the owner's home can be connected as smart loads. To ensure that this product maximizes the benefits to users, it is recommended that the high-power equipment be connected as smart loads (heat pumps, pool heaters, clothes dryers, etc.), which can be cut off when the energy storage system has low power. Other low-power equipment are connected as household loads (lights, routers, etc.)
- It is recommended to use Fast Ethernet and WLAN for communication with inverters. When free 4G traffic of CommMod runs out, users must replace an SIM card.

Partial home backup system wiring diagram

Single inverter (Gateway has the circuit breaker for connecting smart load/diesel generator)

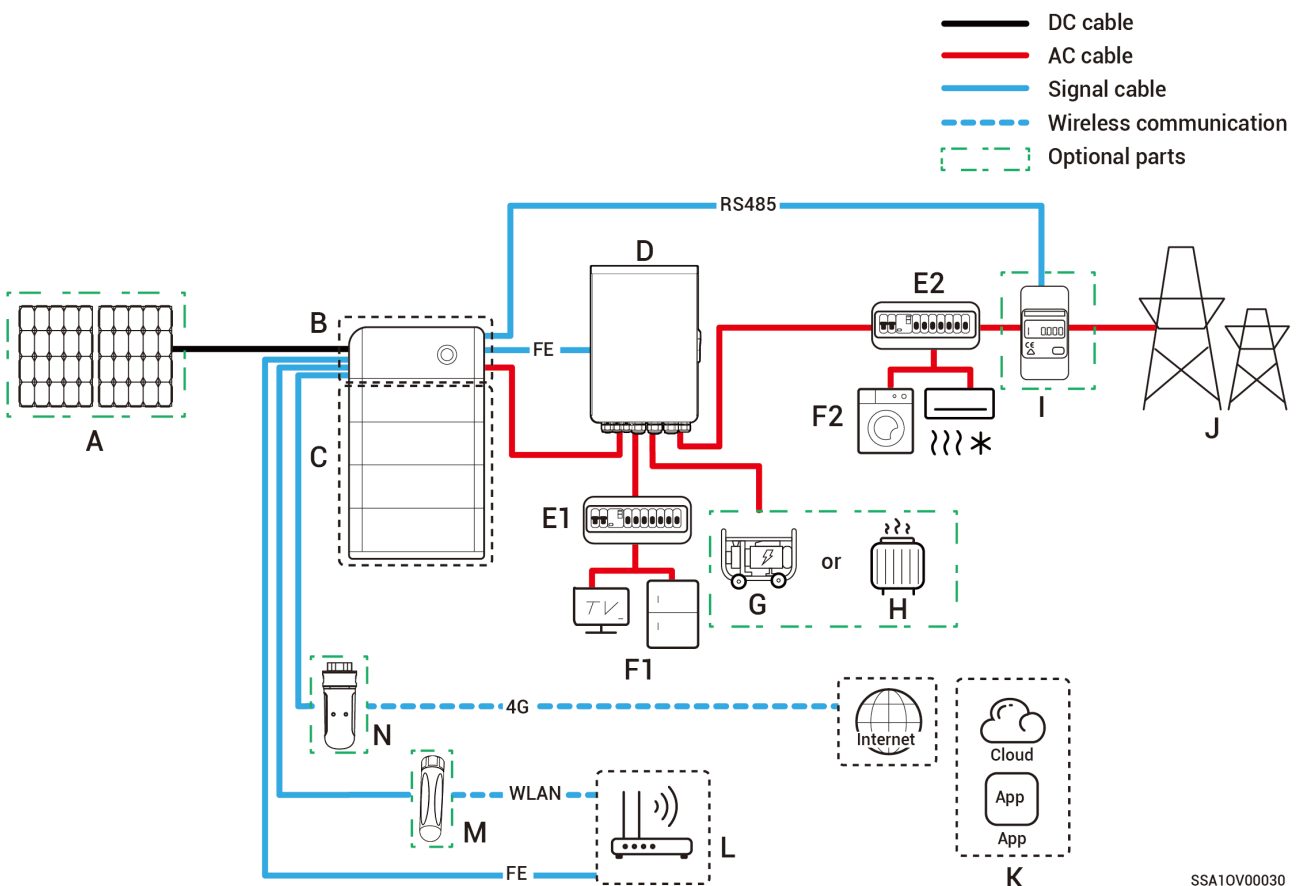

SSA10V00030

Single inverter (Gateway does not have the circuit breaker connected to the smart load/diesel generator)

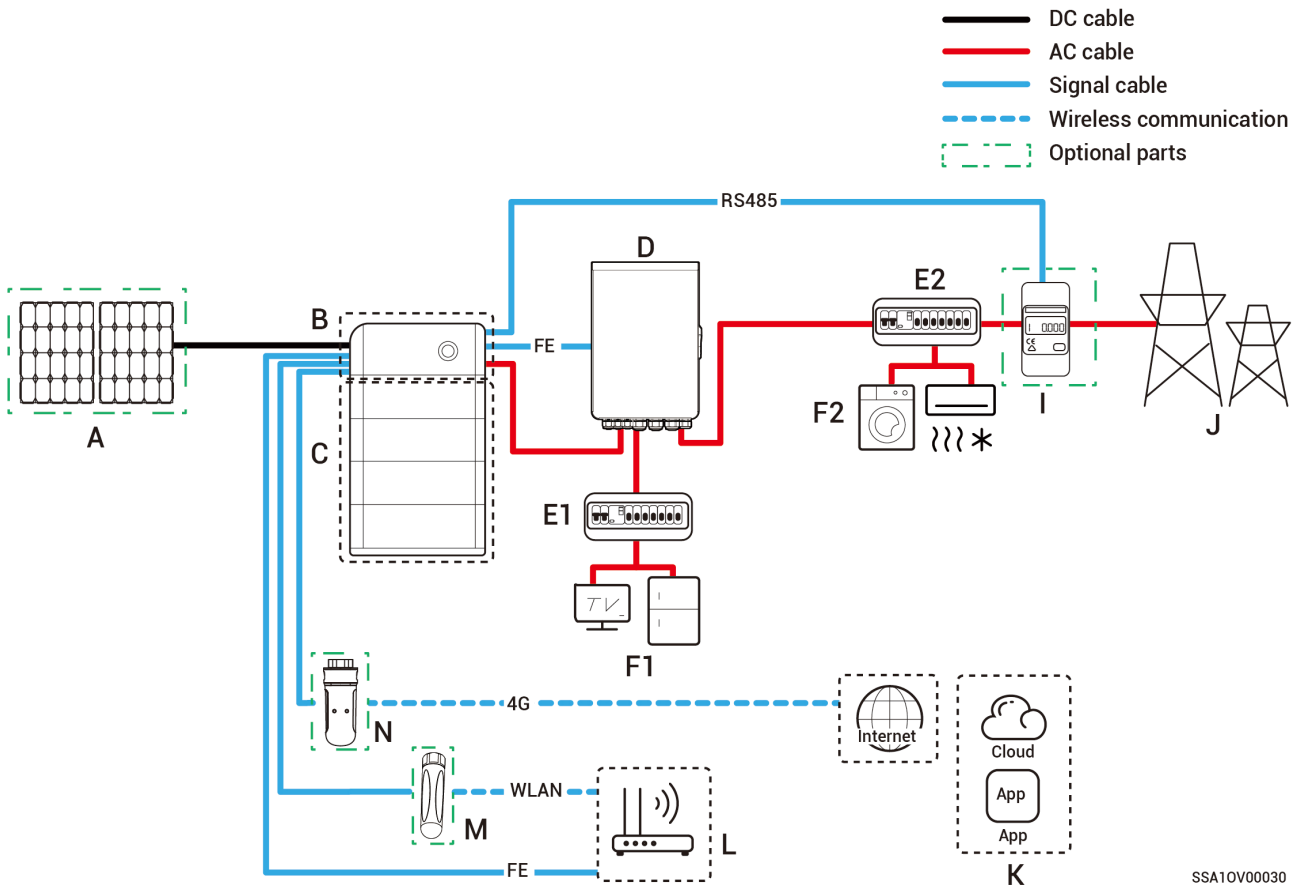

SSA10V00030

Multiple inverters (Gateway does not have the circuit breaker connected to the smart load/diesel generator)

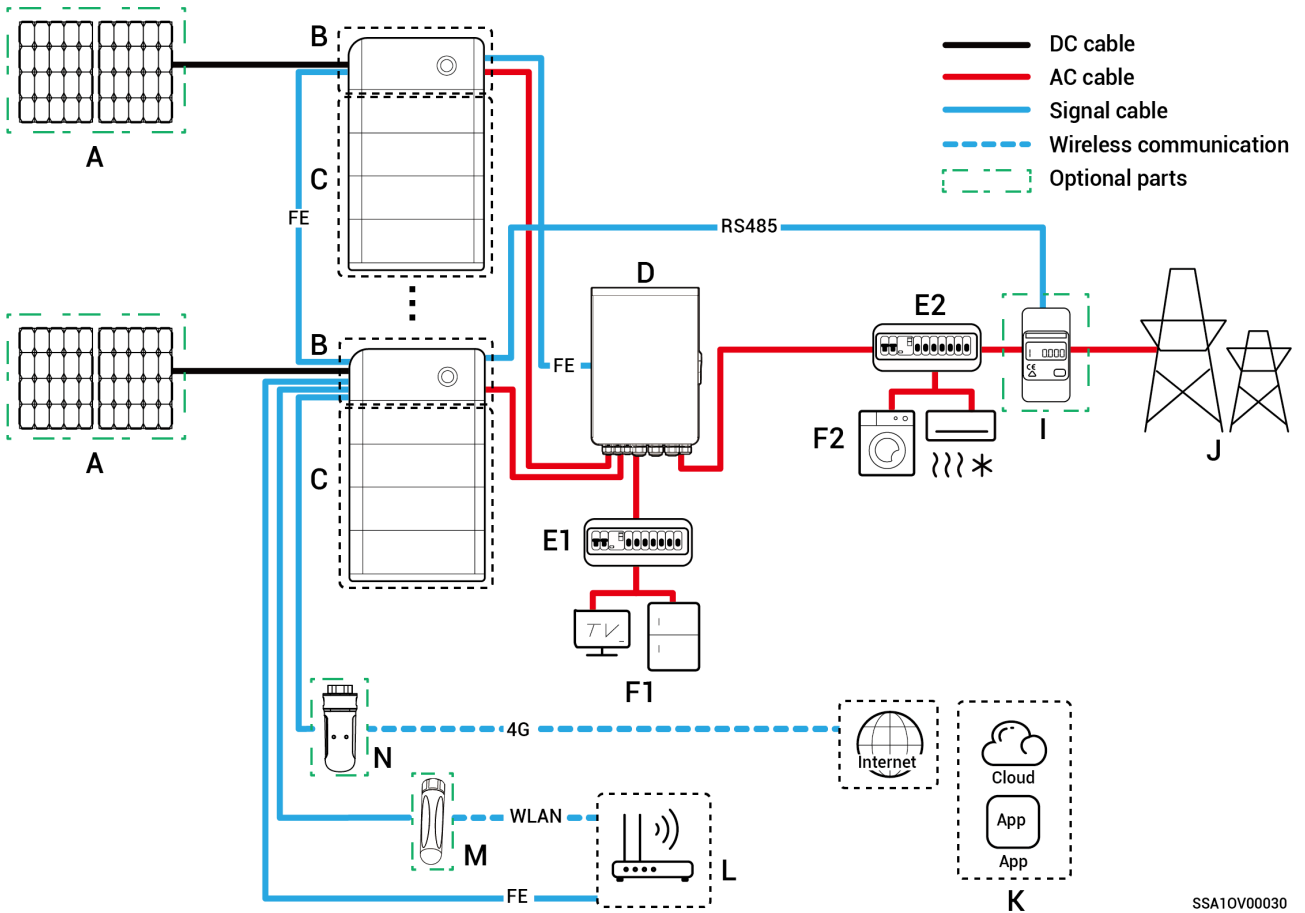

SSA10V00030

No.	Description	No.	Description	No.	Description
A	PV panel	B	SigenStor EC/ SigenStor AC / Sigen Hybrid	C	SigenStor BAT
D	Gateway	E1	Backup Distri- bution panel	E2	Non-Backup Distribution panel
F1	Backup House- hold loads	F2	Non-Backup Household loads	G	Diesel Genera- tor
H	Smart loads	I	Power sensor	J	Power grid
K	mySigen	L	Router	M	Antenna
N	CommMod				

Tips

- If E2 (non-backup distribution panel) features leakage protection, it is recommended that the rated residual operating current be greater than or equal to the number of inverters \times 100 mA.
- If F1 (backup household load) experiences leakage, it may pose a risk of electric shock. In order to avoid this hazard, a residual current device (RCD) must be installed between the D (Gateway) and the F1 (backup household load).
- As a backup energy source for long-term off-grid applications, the diesel generator can work in tandem with the Gateway to provide a smooth transition between PV, storage and diesel power generation.
- All the power equipment in the owner's home can be connected as smart loads. To ensure that this product maximizes the benefits to users, it is recommended that the high-power equipment be connected as smart loads (heat pumps, pool heaters, clothes dryers, etc.), which can be cut off when the energy storage system has low power. Other low-power equipment are connected as smart loads (heat pumps, pool heaters, clothes dryers, etc.), which can be cut off when the energy storage system has low power. Other low-power equipment are connected as household loads (lights, routers, etc.)
- Power sensor has the function of data acquisition for grid connection points enables zero-power grid connection. For partial home backup system wiring, Power sensor does not need to be configured. For partial backup power and zero-power grid connection control system wiring, Power sensor is configured.
- It is recommended to use Fast Ethernet and WLAN for communication with inverters. When free 4G traffic of CommMod runs out, users must replace an SIM card.

Chapter 3 Location Requirements

Tips

- Sigen Gateway TPLV C30-2, Sigen Gateway C60-2, Sigen Gateway C60 AU, Sigen Gateway (C120-6, TPLV C70-6) can be installed indoors and outdoors, Sigen Gateway (C180-9, C300-12), Sigen Gateway (C600, C1200, C600-B, C1200-B) can be installed indoors only. Install the equipment in strict accordance with installation instructions given in this section and local laws and regulations.
- The warranty applies when the equipment has been installed properly for its intended use and in accordance with the operating instructions.
- During actual installation, the selection of installation location should comply with local firefighting, environmental protection regulations, and other relevant laws. The specific installation location planning should be subject to the installer or engineering, procurement, and construction (EPC) contracts.

Installation Environment Requirements

- Do not install the equipment in a smoky, flammable, or explosive environment.
- Do not install the equipment in an environment with conductive metal dust or magnetic dust.
- Do not install the equipment in an environment that is prone to mold and fungi.
- Avoid exposing the equipment to direct sunlight, rain, standing water, snow, or dust. Install the equipment in a sheltered place. Take preventive measures in operating areas prone to natural disasters such as floods, mudslides, earthquakes, and typhoons.
- Do not install the equipment in an environment with strong electromagnetic interference.
- The temperature and humidity of the installation environment should meet equipment requirements.
- The equipment should be installed in an area that is at least 500 m away from corrosion sources that may result in salt or acid damage (corrosion sources include but are not limited to seaside, thermal power plants, chemical plants, smelters, coal plants, rubber plants, and electroplating plants).
- In areas with good marine environments (such as Norway, where the nearshore salinity is ≤ 28 psu), the mounting distance of the device from the coastline can be appropriately relaxed to ≥ 200 m.
- If the outer surface of the device is damaged, please repaint the device in time.

Installation Location Requirements

- Do not tilt the equipment or place it upside down. Ensure that the equipment is horizontally installed.
- Do not install the equipment in a place with fire hazards or is prone to moisturizing.
- Do not install the equipment in a sealed, poorly ventilated location without fire protection measures and difficult access for firefighters.
- Do not install the equipment under water sources, including but not limited to water pipes and air conditioner outlet windows, where condensate or water leakage may occur. Otherwise, liquid may enter the equipment and cause short circuit.

- Do not install the equipment in mobile scenarios such as recreational vehicles, cruise ships, and trains.
- The equipment is hot when it is operating. If the equipment is installed indoors, please ensure good indoor ventilation and avoid significant indoor temperature rise by more than 3°C while the equipment is operating. Otherwise, the equipment will be derated.
- The equipment generates heat when it is operating. Do not install the equipment in areas easily accessible to heat dissipation surfaces.
- You are advised to install the equipment in a location where you can easily access, install, operate, maintain it, and view the indicator status.
- The on-grid/off-grid switchover makes noise. It is recommended that the equipment be installed near the AC distribution box, away from the rest area.

Installation Base Requirements

- Do not install the equipment on a flammable base.
- The installation base should meet the load-bearing requirement and should be free of adverse geological conditions including but not limited to rubber soil and soft soil. Solid brick-concrete structures and concrete walls are recommended.
- The installation base should be flat, and the installation area should meet the installation space requirements.
- No plumbing or electrical alignments should be inside the installation base to avoid potential drilling hazards during equipment installation.

Sigen Gateway TPLV C30-2, Sigen Gateway C60-2, Sigen Gateway C60 AU

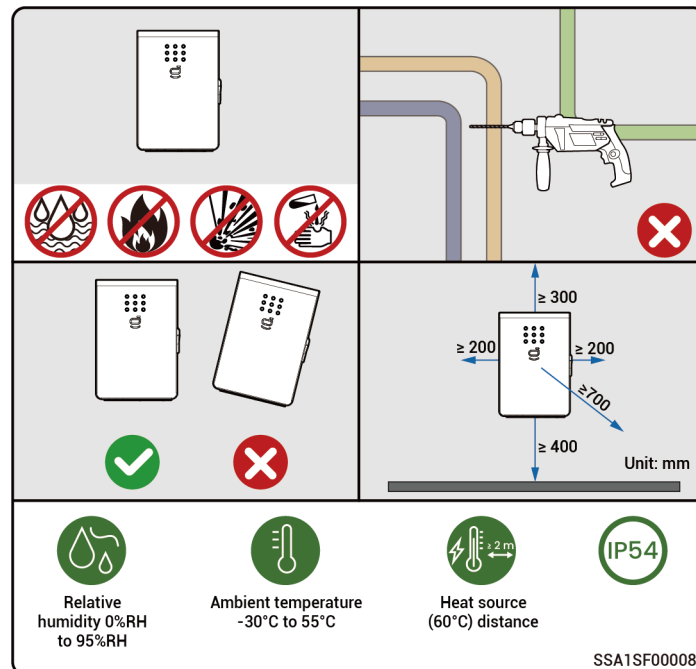

Sigen Gateway C120-6, TPLV C70-6)

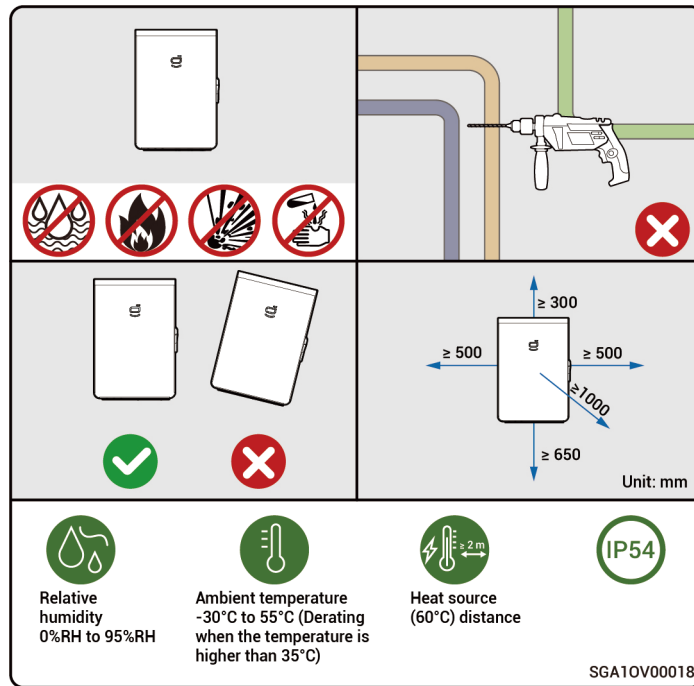

Sigen Gateway (C180-9, C300-12)

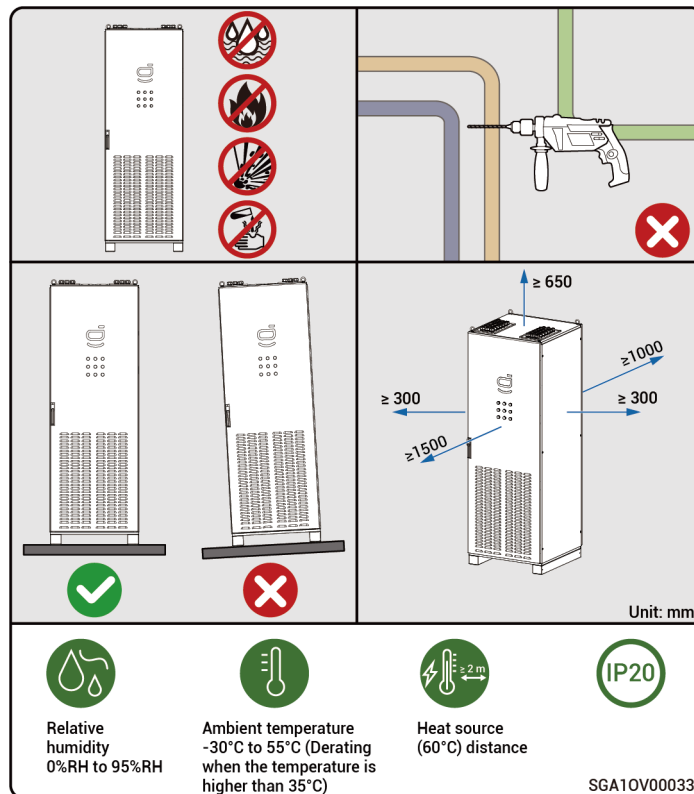

Sigen Gateway (C600, C1200, C600-B, C1200-B)

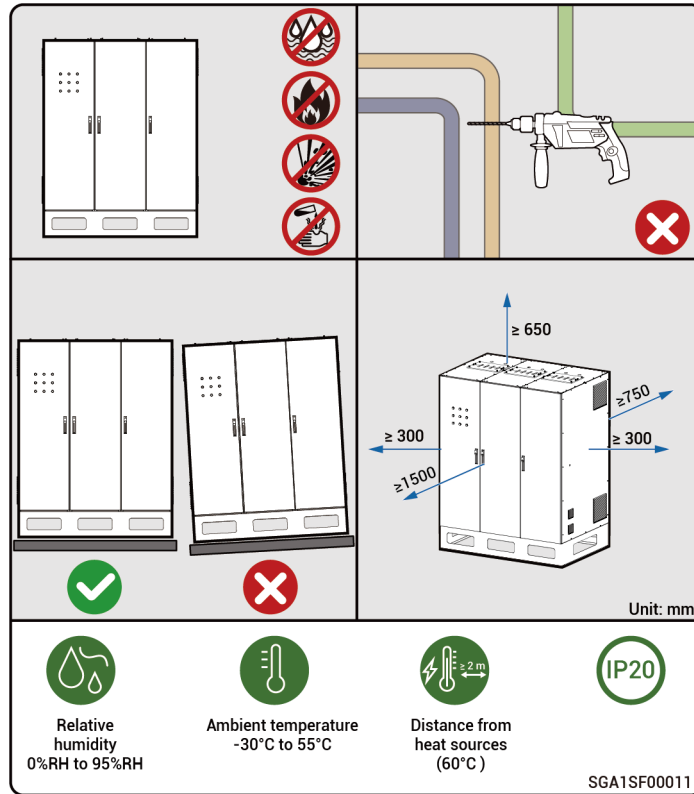

Chapter 4 Equipment Installation and Wiring

- Equipment installation and connection must only be completed by the installer certified by the Company. For more information on the installation procedure, please refer to the Installation Guide of the respective Gateway mode.
- Parts and accessories supplied with the packing box are the property of the purchaser and must be kept safe.

Chapter 5 Searching for App

You can download the App using the following methods. For more information, refer to the App User Manual.

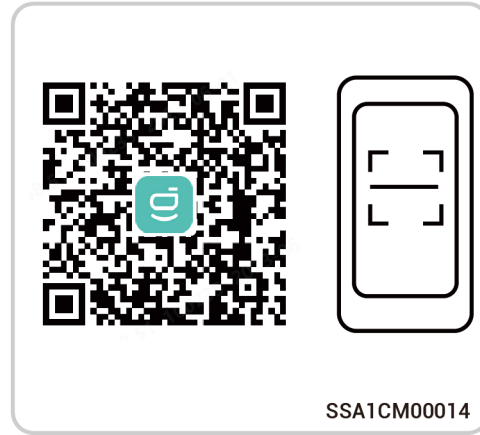

Chapter 6 System Maintenance

Danger

Do not perform operations on the equipment with power on. Before operation, please make sure all power supplies to the equipment have been disconnected, including but not limited to the grid side, inverter and Generator power switches.

6.1 Equipment Power-Down

Warning

- When the equipment is faulty, disconnect all circuit breakers in the equipment immediately, and check and remove the fault before turning it on again.
- Do not operate circuit breakers that are not connected to corresponding equipment when the equipment is powered off. Keep these circuit breakers disconnected.

6.1.1 Sigen Gateway TPLV C30-2

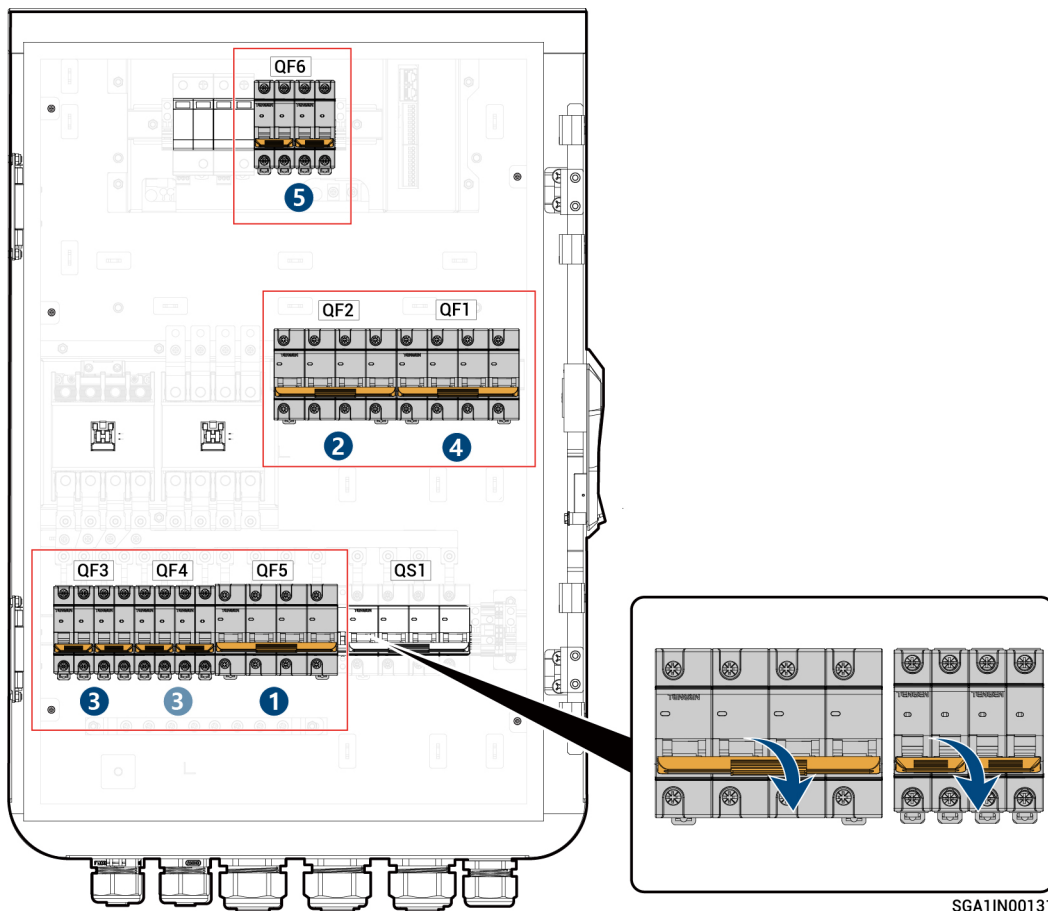

 **Warning**

The Gateway should be disconnected in the following order:

1. Turn off the molded case circuit breaker QF5 (connecting to a backup load).
2. Turn off the molded case circuit breaker QF2 (connecting to a diesel generator/Smart Load).
3. After shutting down the inverter on the phone, turn off the molded case circuit breaker QF3 or QF4 (connecting to an inverter).
4. Turn off the molded case circuit breaker QF1 (connecting to the power grid).
5. Turn off the surge protective device switch QF6.

6.1.2 Sigen Gateway C60-2

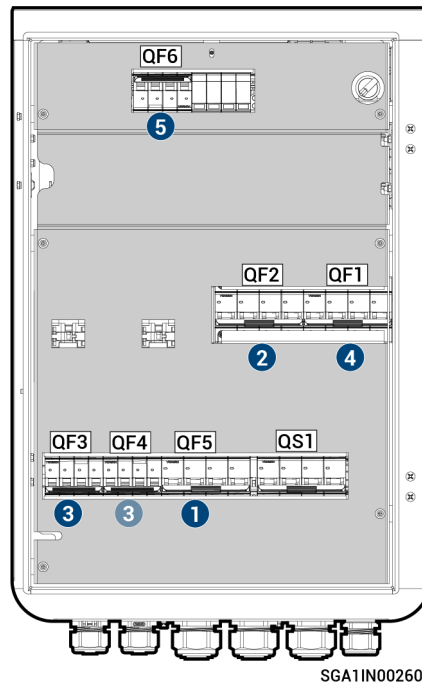

Warning

The Gateway should be disconnected in the following order:

1. Turn off the miniature circuit breaker QF5 (connecting to Backup loads).
2. Turn off the miniature circuit breaker QF2 (connecting to Smart loads/Generator).
3. After shutting down the inverter on the phone, turn off the miniature circuit breaker QF3, QF4 (connecting to an inverter).
4. Turn off the miniature circuit breaker QF1 (connecting to the Power grid).
5. Turn off the miniature circuit breaker QF6 (connecting to the Surge Protection Device).

6.1.3 Sigen Gateway C60 AU

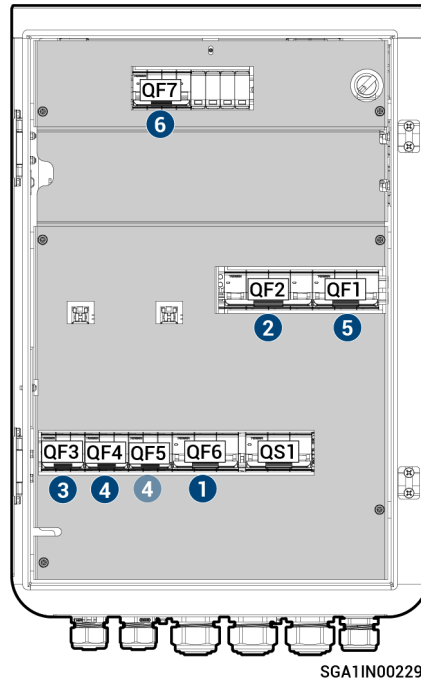

Warning

The Gateway should be disconnected in the following order:

1. Turn off the miniature circuit breaker QF6 (connecting to Backup loads).
2. Turn off the miniature circuit breaker QF2 (connecting to Smart loads/Generator).
3. After shutting down all the inverters on the phone, turn off the miniature circuit breaker QF3 (connecting to the inverter 1).
4. Turn off the miniature circuit breaker QF4 or QF5 (connecting to the inverter 2).
5. Turn off the miniature circuit breaker QF1 (connecting to the Power grid).
6. Turn off the miniature circuit breaker (connecting to the Surge Protection Device) QF7.

6.1.4 Sigen Gateway (C120-6, TPLV C70-6)

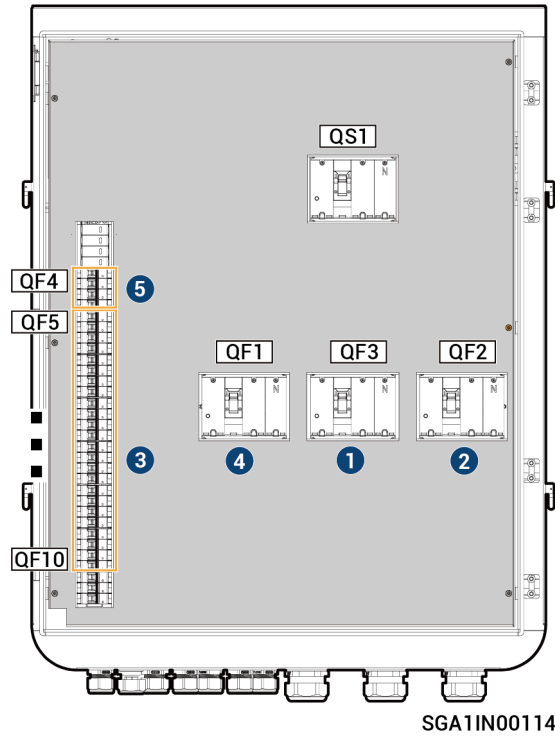

Warning

The Gateway should be disconnected in the following order:

1. Turn off the molded case circuit breaker QF3 (connecting to a backup load).
2. Turn off the molded case circuit breaker QF2 (connecting to a diesel generator/smart Load).
3. After shutting down the inverters on the phone, turn off the molded case circuit breakers QF5–QF10 (connecting to an inverter).
4. Turn off the molded case circuit breaker QF1 (connecting to the power grid).
5. Turn off the surge protective device switch QF4.

6.1.5 Sigen Gateway (C180-9, C300-12)

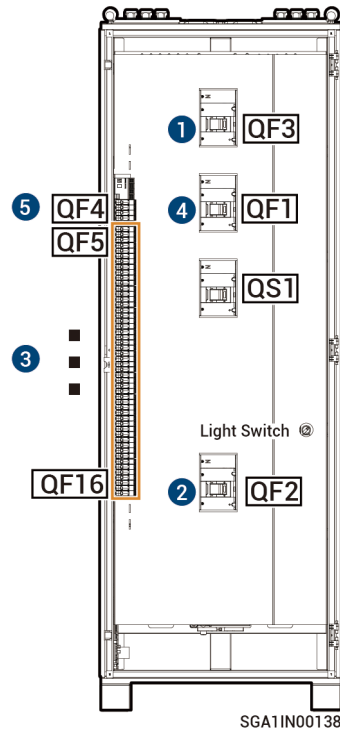

Warning

The Gateway should be disconnected in the following order:

1. Turn off the molded case circuit breaker QF3 (connecting to a backup load).
2. Turn off the molded case circuit breaker QF2 (connecting to a diesel generator/smart Load).
3. After shutting down the inverters on the phone, turn off the molded case circuit breakers QF5–QF16 (connecting to an inverter).
4. Turn off the molded case circuit breaker QF1 (connecting to the power grid).
5. Turn off the surge protective device switch QF4.

6.1.6 Sigen Gateway (C600, C1200, C600-B, C1200-B)

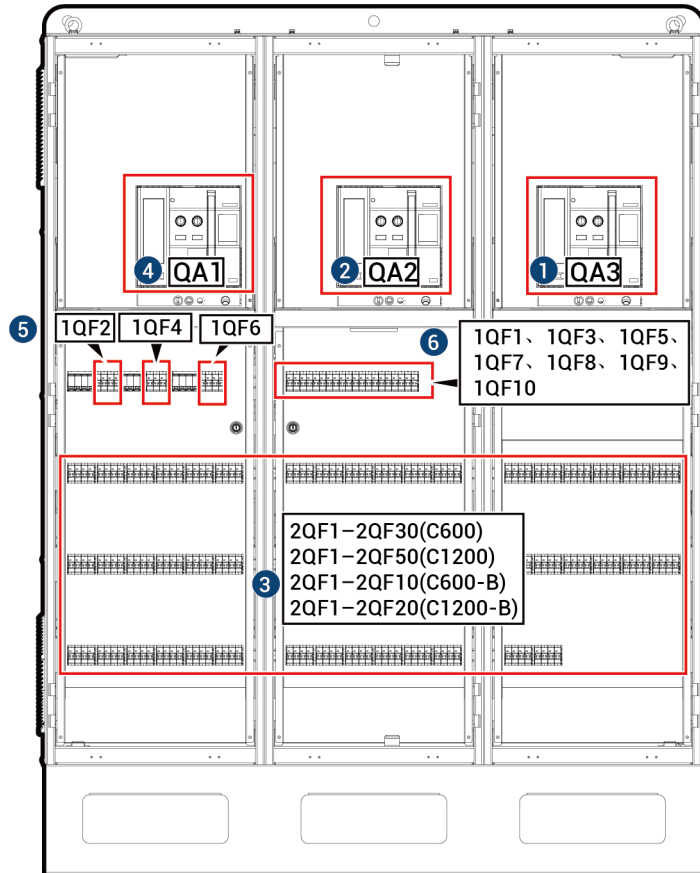

SGA1IN00169

Warning

The Gateway should be disconnected in the following order:

1. Turn off the frame circuit breaker QA3 (connecting to a backup load).
2. Turn off the frame circuit breaker QA2 (connecting to a diesel generator/Smart Load).
3. After shutting down the inverters on the phone, turn off breakers (connecting to inverters).
 - C600 : turn off 2QF1~2QF30 (miniature circuit breaker)
 - C1200: turn off 2QF1~2QF50 (miniature circuit breaker)
 - C600-B: turn off 2QF1~2QF10 (molded case circuit breaker)
 - C1200-B: turn off 2QF1~2QF20 (molded case circuit breaker)
4. Turn off the frame circuit breaker (connecting to the power grid) QA1.
5. Turn off the surge protective device switch 1QF2, 1QF4 and 1QF6.
6. Turn off the PCB board secondary control switch 1QF1, 1QF3, 1QF5, turn off the secondary control switch of frame circuit breaker 1QF7, 1QF8, 1QF9, 1QF10.

6.2 Routine Maintenance

To ensure the long-term operation of the equipment, you are advised to perform routine maintenance according to this section.

Inspection Items	Inspection Method	Power Off or Not	Maintenance Interval
System cleaning	Check the device regularly for shielding and dirt. If so, clean it up. Do not use tools that may cause electric shock or insulation damage, such as wire brushes and during the cleaning process.	Yes	Once every 3 months
System operating state	<ul style="list-style-type: none"> ● Check whether the equipment appearance is damaged or deformed. ● Check for noise when the equipment is operating. ● Check whether the equipment parameters are correctly set when the equipment is operating. 	No	Once every 6 months
Electrical connection	<ul style="list-style-type: none"> ● Check whether cable terminals are tightly connected. ● Check whether cable sheath is damaged. ● Check whether scratches exist on the surface where the cable contacts the metal. ● Check whether scratches exist on the surface where the cable contacts the metal. ● Check whether unused routing holes are sealed. 	Yes	Check once every 6 months after creating new systems and once every 6 to 12 months thereafter.

Inspection Items	Inspection Method	Power Off or Not	Maintenance Interval
Grounding reliability	Check whether the ground cable is properly and reliably connected.	No	Check once every 6 months after creating new systems and once every 6 to 12 months thereafter.

6.3 Common Fault Troubleshooting

Fault	Cause Analysis	Corrective Action
The inverter repeatedly shuts down/restarts in off-grid mode	<ul style="list-style-type: none"> ● The backup load is greater than the rated power of the inverter. ● The bypass switch is turned on by mistake. 	<ul style="list-style-type: none"> ● Turn off some power equipment to ensure the load is not greater than the rated power of the inverter. ● Turn off the bypass switch. ● If the problem persists, please contact our technical support.
The red indicator of the OCR controller is on (only for Sigen Gateway (C600, C1200, C600-B, C1200-B))	Tripping due to non-human reasons such as overload, short circuit, grounding, undervoltage, etc.	Please refer to the user manual of the frame circuit breaker for the corresponding gateway model, confirm the cause of the switch tripping, and eliminate the fault. The above operations must be performed with proper personal safety protection, in compliance with the insulation requirements of relevant equipment, and with 2 or more people present.

6.4 Operations on Bypass Switch

Tips

In normal cases, the bypass switch is turned off. Do not operate the bypass switch. In this case, the Gateway can automatically switch between on-grid and off-grid.

6.4.1 Steps for Closing the Bypass Switch

Tips

When the backup power cabinet malfunctions and cannot supply power to the load, the bypass switch can be closed to supply power to the load through the grid.

Operation Steps

1. Confirm that the grid side has power.
2. Refer to "Device Power-Off" to complete the power-off operation.
3. Refer to the delay label on the device, wait for the corresponding time, remove the spring clip from the bypass switch, and then close the bypass switch.

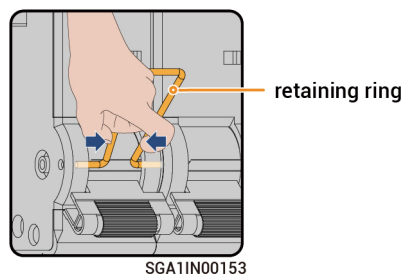

Warning

- After the device is powered off, residual current and residual heat remain. Immediate operation after power-off may cause electric shock and burns.
- The device carries high voltage. Please wear insulated gloves when closing the switch.

Caution

After the bypass switch is closed, do not close the miniature circuit breakers connected to the inverter and generator on the backup power cabinet, as this may energize the grid port and pose an electric shock risk.

4. Close the miniature circuit breaker connected to the surge protector.
5. Close the miniature circuit breaker connected to the grid.
6. Close the miniature circuit breaker connected to the household backup power load.

7. Close the equipment cabinet door.

6.4.2 Procedure for disconnecting the bypass switch

Tips

If the bypass switch is accidentally closed due to misoperation, you can disconnect the bypass switch and then power on the inverter and backup power cabinet.

1. Troubleshoot the fault.
2. Disconnect the bypass switch.
3. Refer to the maintenance guide for the corresponding inverter model to complete the inverter power-on operation.
4. Refer to the installation guide for the corresponding backup power cabinet model to complete the backup power cabinet power-on operation.

6.5 Emergency Measures

Fire Emergency Measures

Danger

- Shut down the equipment or cut off the mains switch if it is safe to do so.
- If the fire is small, use a carbon dioxide or ABC dry powder fire extinguisher to extinguish the fire.
- If the fire is spreading, evacuate from the building or equipment area immediately and call the fire department. Do not go back inside the building.
- Do not expose firefighters to high-voltage components during firefighting. Otherwise, the risk of electric shock may exist.
- Do not use the equipment after extinguishing the fire. Please contact your installer.

Flood Emergency Measures

Danger

- Shut down the equipment or cut off the mains switch if it is safe to do so.
- Do not use the equipment after the floodwaters recede. Please contact your installer.

Chapter 7 Technical Parameters

For more information on the parameters of the equipment, please refer to their respective data sheets.